



# ACE

any cable everywhere



## user guide

version 1.4.3

17. September 2024

<b>Introduction</b>	<b>4</b>
Installation.....	4
ACE Concept and Features.....	5
<b>User Interface</b>	<b>6</b>
Default Signal Flow.....	6
Control Bar.....	7
GUI Elements.....	9
<b>Patch Browser</b>	<b>11</b>
Overview.....	11
Directory Panel.....	12
Presets Panel.....	15
Drag & Drop.....	16
Patch Info.....	17
Installing Soundsets.....	18
Preset Tagging.....	19
Search by Tags.....	20
Search by Text.....	21
<b>Modules</b>	<b>23</b>
Oscillators (common parameters).....	23
VCO1.....	24
VCO2.....	25
LFO1.....	26
LFO2.....	28
MIX.....	29
VCF.....	30
ADSR.....	32
Ramp Generator.....	33
Multiplex.....	33
VCA.....	35
Signal Sources.....	36

<b>General Settings</b>	<b>37</b>
Polyphony and Quality .....	37
Pitch Settings .....	38
<b>Effects</b>	<b>39</b>
Chorus .....	39
Delay .....	40
Tone controls .....	41
Effects On/Off .....	41
<b>Tweak Page</b>	<b>42</b>
Mapping Generator .....	42
Stacked Voice Tuning .....	45
Circuit Bending .....	45
Envelope Tweaks .....	46
Microtuning .....	47
<b>Configuration</b>	<b>48</b>
MIDI Control .....	48
Preferences .....	52
<b>MIDI Specialities</b>	<b>55</b>
MIDI Programs .....	55
CLAP .....	55
Polyphonic Aftertouch .....	55
Multichannel MIDI .....	55
MPE .....	56

# Introduction

## Installation

---

Go to the ACE webpage at [www.u-he.com](http://www.u-he.com), download the appropriate installer for your system, and unzip the compressed file. Open the “ACE” folder and start the installer application. The only demo restriction is a crackling sound at irregular intervals after about two minutes of use. This disappears after you enter a serial number.

For more information, including our terms of use, please refer to the text files that came with the installer (click on the **u-he** badge and select *Docs Folder*).

By default, ACE uses the following directories:

### Windows

presets (local)	<code>C:\Users\*YOU*\Documents\u-he\ACE.data\Presets\ACE\</code>
presets (user)	<code>C:\Users\*YOU*\Documents\u-he\ACE.data\UserPresets\ACE\</code>
preferences	<code>C:\Users\*YOU*\Documents\u-he\ACE.data\Support\ (*.txt files)</code>
alternative skins	<code>C:\Users\*YOU*\Documents\u-he\ACE.data\Support\Themes\</code>
microtuning	<code>C:\Users\*YOU*\Documents\u-he\ACE.data\Tunefiles\</code>

### Mac

presets (local)	<code>Macintosh HD/Library/Audio/Presets/u-he/ACE/</code>
presets (user)	<code>*YOU*/Library/Audio/Presets/u-he/ACE/</code>
preferences	<code>*YOU*/Library/Application Support/u-he/com.u-he.ACE... (*. files)</code>
alternative skins	<code>Macintosh HD/Library/Application Support/u-he/Themes/</code>
microtuning	<code>Macintosh HD/Library/Application Support/u-he/Tunefiles/</code>

## online resources

For downloads, news articles and support, go to the [u-he website](http://www.u-he.com)

For lively discussions about u-he products, go to the [u-he forum](http://www.u-he.com/forum)

For friendship and informal news updates, go to [u-he facebook](https://www.facebook.com/uhe)

For video tutorials and more, go to the [u-he youtube channel](https://www.youtube.com/channel/UC...)

For our soundsets and bundles, go to [u-he soundsets](http://www.u-he.com/soundsets)

For 3rd party presets, go to [Patchlib](http://www.patchlib.com)

## u-he team 2025 (Q4)

Urs Heckmann (concepts, code); Jayney Klimek (accounting, procurement); Howard Scarr (sound design, user guides, grump); Sebastian Greger (UI design, 3D graphics); Jan Storm (framework, hardware code); Oddvar Manlig (business development); Viktor Weimer (customer support, sound design); Thomas Binek (QA, betas, customer support); Henna Gramentz (accounting, customer support); Frank Hoffmann (framework, browser); Alf Klimek (studio, voiceovers); Sebastian Hübner (media); David Schornsheim (framework, CLAP); Kay Knofe (hardware development); Tim Fröhlich (code); Sadjad Siddiq (DSP); Petros Karagkounidis (web development,); Simon Schrape (web development), Max Steimel (DSP); Henry Lau (accounting, customer support); Mine Hahn (DSP), Vadim Zavalishin (filter design, DSP)...

Special thanks to Brian Rzycki for maintaining the [original patch library](http://www.patchlib.com)

# ACE Concept and Features

---

## modular ultrasound

Most digital synths handle audio signals and modulation signals separately. Audio is usually evaluated at a rate between 44100 and 96000 Hertz, while modulation signals update at 1000 Hz or slower (often called the "control rate" of the synthesizer).

ACE is different in this respect. While the oscillators have more than 500 times oversampling, all signals (including modulation) run at least twice as fast as the host application's sample rate... and this is just the lowest of ACE's quality settings.

ACE does not differentiate between audio signals and modulation/control signals. You can plug any signal output into any signal inputs and expect it to work just like vintage modular hardware. So any modulation can function beyond the limits of human hearing. For instance, the LFOs (low frequency oscillators) can be sent above 20 kHz and still modulate e.g. the pulse width of another oscillator. This gives you a sonic freedom previously reserved for expensive analogue hardware. Both LFOs can be used as audio oscillators e.g. for FM (frequency modulation) sounds. Conversely, the VCOs (voltage controlled oscillators) can be used as alternative LFOs. Note: Any DC (direct current) is removed from VCO outputs, so when used as LFOs their shapes may not be precisely as you might expect.

## analogue modeling

Wherever necessary, the non-linear characteristics of analogue circuitry has been programmed directly into the code. For instance, the filter algorithm is built around a very precise mathematical model of a hardware analogue filter – as are the basic components of the oscillators and envelope generators.

Only the LFOs, mixer, ramp generator and control-signal conversions are not analogue models. You will soon hear why: unlike its analogue ancestors, ACE is not susceptible to instabilities, and all the oscillators can be synchronized to song tempo. In ACE, even perfect host-synchronized beating between two oscillators is possible.

Non-linear distortion in the self-oscillating filters, extremely fast envelopes and modulation channels (as well as other unique details such as "Glide2" and "Tap Map") open up a myriad of sound-sculpting techniques unavailable in other software synths.

If you really want to compare ACE to a classic modular synth (or three), think of it as a pimped-up ARP 2600 using modules from a Roland SH-7 with (almost) the patching flexibility of an EMS VCS3 / Synthesi A – but polyphonic. Just like the ARP 2600, ACE is pre-patched so that it will work out-of-the-box, but these default connections can be overridden by plugging in patch cables.

Many of the modules were designed to carry out a number of seemingly unrelated tasks. For instance the ramp generator can be used as an LFO, the multiplexes as ring or amplitude modulators, LFO1 as a waveshaper, or the filters as slew limiters...

# User Interface

You should feel very comfortable with ACE – it was designed to pack a lot of functionality into a compact but clear user interface.

## Default Signal Flow

Like e.g. the ARP 2600, but unlike most other real modular systems, you don't need to plug any cables in before you can get a squeak out of ACE – that's because the modules are already connected in the typical configuration of a fixed architecture synthesizer by default. Of course the real fun begins when you dip into your "infinite" supply of cables and start overriding those defaults, connecting modules together any way you like...

### ACE signal flow without any patch cords

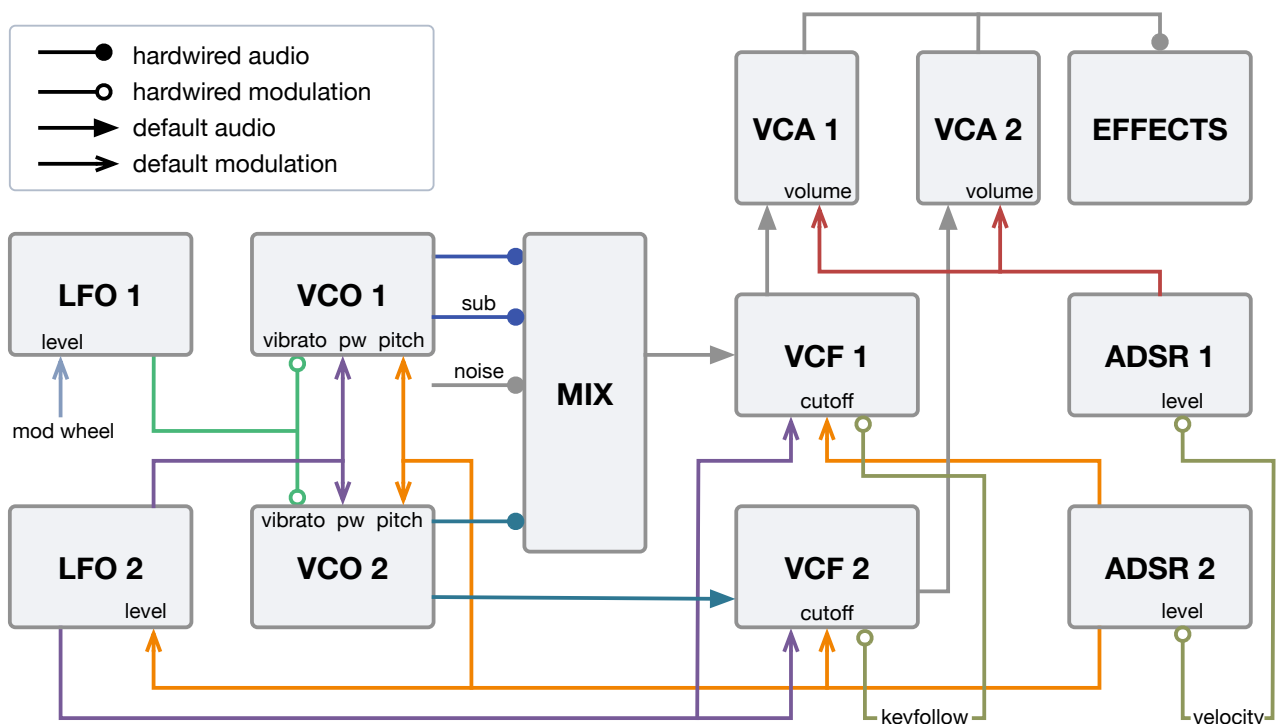

VCO1 and sub-oscillator, VCO2 and white noise are MIXed and routed to VCF1, which is in turn routed to VCA1 (to right of the oscilloscope, unlabeled). Similarly, VCO2 is sent through VCF2 to VCA2.

LFO1 is hardwired as the source of vibrato for both VCOs. The output level of LFO1, and therefore vibrato depth, is controlled by the mod wheel (MIDI CC#1). LFO2 modulates both VCO pulse width values as well as both VCF cutoff values.

ADSR1 (red) is used as the envelope generator for both VCAs. ADSR2 (orange) modulates both VCO frequencies, both VCF cutoffs and the output level of LFO2.

## Control Bar

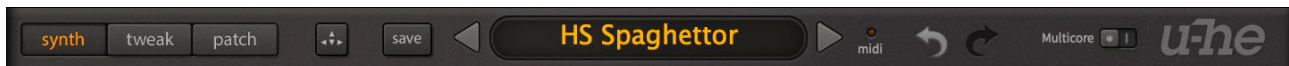

The strip along the top is home to several indicators and controls:

### synth | tweak | patch

Select the synthesis page, the so-called Tweak page or the patch (preset) browser.

### key control

Experimental feature, work in progress! For various reasons we recommend using a numeric keypad a.k.a. numpad.



Activate the button, then either click on a control or navigate using the cursor keys. Type a numerical value, then confirm via *enter*. For negative values, type *minus* (-) before confirming. Hit *backspace* to recall the default value.

Increment / decrement integer values via plus (+) and minus (-) in the numpad. Hold *shift* for fine control, or *option* (Mac) / *ctrl* (Win) key for steps of 10.

The system copy/paste and undo/redo shortcuts work.

Remote control tip: In the [MIDI Table](#), add Last Clicked Control as Parameter and specify a Controller ([MIDI CC](#)) you can send from a knob or slider on your hardware.

For more details about this feature, including a video walkthrough, go to:

<https://www.kvraudio.com/forum/viewtopic.php?t=611856>.

### save

Right-click on the **[save]** button to check the format in which patches will be saved. The default is u-he's cross-platform *.h2p* format. To save patches in the host-specific format, select *native* here. We strongly recommend using the standard *.h2p* so that you can exchange patches freely between any platforms. The *.h2p extended* format is the same as regular *.h2p* except that it also includes per-line comments.

Important: If you have set the [Save Presets To](#) preference to *selected folder* (the default is *user folder*), please make sure that the folder where you want to store your preset is already selected before you save – if not, click on that folder first.

Left-click on the **[save]** button, give your preset a name and enter any other details: Preset description, playing tips etc. – anything you would like to appear in the PRESET INFO panel of the browser. Finally, confirm by clicking on the **[apply]** button.

Tip: If there's a preset called **default** in the local root, it will be loaded instead of the regular demo sound. Try this: Right-click on the data display and select 'init'. Save the patch under the name 'default' and start a fresh instance of ACE.

## data display

The central display shows the name of the selected patch or the value of any parameter as it is being edited. Click on the triangles either side of the display to step through patches. Click on the name in the the display to open a drop-down list of all patches in the current directory. If you drag a preset from outside ACE and drop it onto the data display, that preset will be loaded but not automatically saved.

### initialize patch

Whenever you want to start programming from scratch, right-click on the data display and select 'init' (currently the only entry in that menu). All knobs and switches are reset to their default values – a clean slate!

### revision

Hover over the 'REV' label below the data display to view the core revision number.

## midi

A MIDI activity indicator which flashes whenever ACE is receiving MIDI data.

## undo / redo



The pair of curved arrows to the right of the data display can be used to fix recent mistakes. Although the number of undo steps is limited to 30, you can even undo a change of preset, so that switching presets before saving doesn't mean losing your work.

Note that undo/redo does not work within the [patch browser](#).

## multicore

Activating this option causes ACE to distribute voices across available CPU cores, which **in certain cases** allows more voices to be played without overloading the CPU. This works well on processors such as Intel i5 or i7, but it is always worth checking whether ACE uses more CPU with *multicore* on or off on your system. Also, some host applications offer their own multicore support, and activating both can lead to poorer ACE performance.

## u-he badge

Click on the badge for direct access to our website, to this user guide and other ACE documents, to our user support forum at KVR and to our social network pages.

For details about the final Install Soundset entry, see [Installing soundsets](#).

## Configuration cogwheel



Clicking on the cogwheel symbol at the far right opens the configuration pages where you can set up remote control via MIDI CC as well as several global preferences. See the [Configuration](#) chapter.

## GUI Elements

---

### knobs



ACE has two types of knob: *unipolar* and *bipolar*. Unipolar knobs only allow positive values, usually within a range of 0.00 to 100.00. Bipolar knobs also allow negative values, usually within a range of -100.00 to +100.00 with zero in the central position.

**coarse control:** Click+hold with the lefthand mouse button, then drag up or down.

**fine control:** for steps of 0.01, hold down either SHIFT key before moving the knob.

**mouse wheel:** If your mouse has a scroll wheel, you can hover over a knob and roll the wheel for coarse adjustment. Fine control via SHIFT.

If your mouse wheel is rastered (you can feel it clicking slightly as you roll the wheel), right-click on any knob and select MouseWheel is rastered from the context menu. Each little click will then increment or decrement with a more 'sensible' step!

**default reset:** Double-clicking a knob reverts to a sensible default value, usually 0.00.

Note: All the above also applies to the envelope faders.

### switches

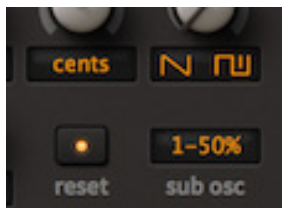

All orange text elements and icons are switches. Many of them also serve as labels for the associated knobs.

Values can be incremented via left-click, a right-click opens the list, and mouse wheel movement scrolls through all values.

### parameter locking



To guarantee that the value of a parameter **doesn't change when you switch presets**, use the Lock function. Right-click on a control and select 'Lock' from the context menu. Please remember this: You are still free to adjust the value of a locked parameter at any time!

### sockets and cables

In most hardware modular synthesizers, standard jack sockets and leads are used to connect modules together. ACE's virtual cables always connect outputs with inputs:

 **OUTPUT** sockets have dark rims

 **INPUT** sockets have lighter rims

To create a connection in ACE, drag and drop between the sockets. Outputs will happily accommodate several patch cables, while inputs will only accept one. Most of the modulation inputs have controls for setting the modulation amount. For instance below LFO1's *Phase* knob is an input socket and control for *phase modulation*.

**daisy chaining:** Although you normally can't connect two inputs together, try dragging a cable from an unused input socket to one that is already in use. It works – the source signal is passed on to all inputs in the chain. The main advantage of daisy chain patching is that patches can appear much less cluttered.

**to change inputs,** drag+drop from the current input to another input.

**to change opacity and style,** right click on any input socket (even an unused one) and select the two properties: Opacity = *solid*, *see-thru*, *x-ray* or *ghosted* and Style = *thick*, *slim*, *line*, *hair* or *natural*. Default options can be set in the [Preferences](#) panel.

**to change outputs,** right-click on the output and drag it to a different output. A straight line will appear. Several cables connected to one output can only be moved together.

**to remove cables,** double-click (or drag away) the input end.

**to change colour,** click on the input end. Take care not to double-click, as this would remove the cable. Colours are initially selected more or less at random so that overlapping cables can be differentiated easily.

## oscilloscope

The oscilloscope displays a mono sum of the output, pre-effects. It is used for e.g. fine adjustments to waveforms, for checking the effects of audio-rate modulation or filtering on the waveform, for viewing envelope shapes etc.. Or simply for its entertainment value!

Oscilloscopes have proved very useful while creating sounds. Especially if the synth has audio-rate modulation – like classic modular systems... and ACE.



ACE's oscilloscope is synchronized to MIDI notes as well as to zero-crossings (negative to positive transitions). The display is updated whenever a longer scan is completed.

As synchronization is automatic, the oscilloscope only requires two controls: **Freq** adjusts the horizontal resolution while **Scale** adjusts the vertical resolution.

Right-clicking in the window lets you switch the drawing mode: **glow**, **fire** and **wind** add different fade-out effects at the cost of some extra CPU. These modes are also slightly more sluggish than **eco** or **fast**. To minimize CPU usage, choose the eco (economical) option. Note: This setting is mirrored in the [Preferences](#).

## GUI size

Right-click anywhere in the background. The size options are measured in percentages and pixels (width x height), and increment in 10% steps from 70% to 200%.

This setting is temporary – to specify a default GUI size, see [Preferences](#).

# Patch Browser

## Overview

ACE presets are sometimes called **patches** \*, a term borrowed by the modular synthesizer community from the early telephone exchange when calls were manually connected via jack cords. You can load any preset in the current folder by clicking on the data display, or step through them by clicking on the arrow symbols either side of the data display.

\* **patch = preset = program**

Of course ACE also includes a preset browser. Clicking on the [patch] button at the top left will open this set of panels:



Folders appear on the left, presets in the centre and information about the currently active one appear on the right. If you can't see any, click on *Local*. If there is no PATCH INFO panel, click on the [≡] button (top right) and select *Show Preset Info*.

The Local root contains a representative selection of presets copied from the sub-folders. After loading a preset you can step through all others using your computer's cursor keys. To access all other factory presets, click on the triangle to the left of the Local folder.

## Default preset

When ACE starts it checks whether the Local root contains a preset called *default*, which is then loaded instead of the demo sound. Note that *default* will not appear in the browser.

If you want ACE to start with a simple template every time instead of the default, do this: Right-click on the data display, select *init* ([initialize](#)) and make any adjustments you like.

Make sure that the preference [Save Presets To](#) is set to 'selected folder' and that the 'Local' root directory is currently open. Finally, [Save] your preset under the name *default*.

## Directory Panel

If you don't see this panel on the left of ACE's patch browser, click on the DIRECTORY tab:

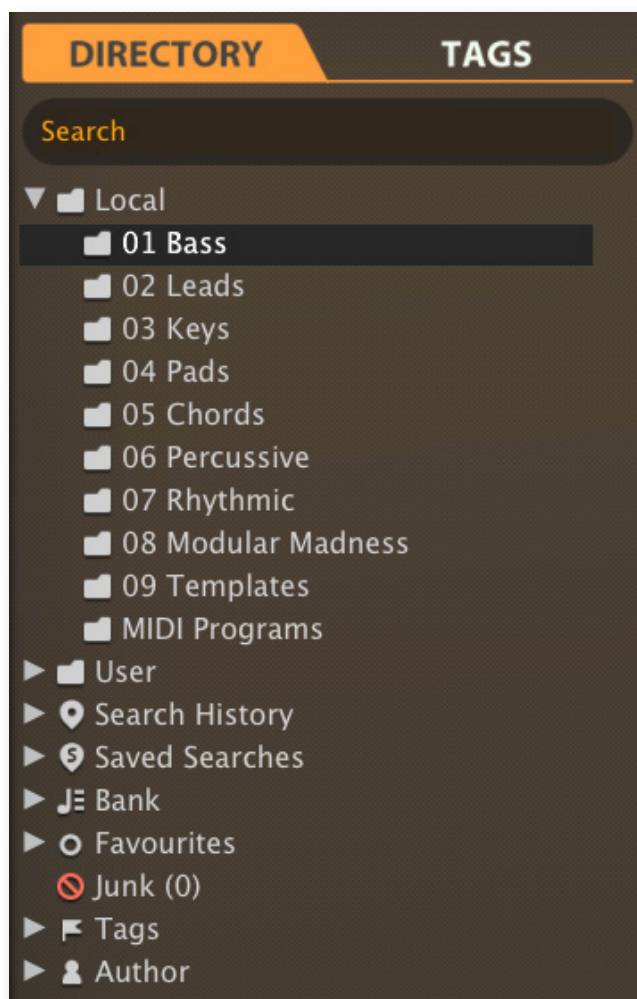

### Local

ACE's factory presets are sorted into folders 01 through 09. We recommend that you do not add or remove presets here, but save all your creations in the 'User' folder (see below). See also the preference [Save Presets To](#).

As well as the categorized factory presets, *Local* also contains a special folder called 'MIDI Programs', which is initially empty. For details, see the [MIDI Specialities](#) chapter.

### User

The best address for your own creations as well as soundsets from any other sources. You can select the *User* folder immediately before saving the preset, or set a global preference which ensures that it will always be saved somewhere within this folder – see the [Save Presets To](#) preference.

Tip: It's worth finding out where the User folder resides on your computer, especially if you want to manually install soundsets. Simply right-click on the *User* folder and select *Open in Finder / Explorer*.

## Smart Folders

The other folders do not contain files, but display the results of querying a database of presets. The content is dynamic i.e. it will reflect any changes in the underlying data.

You can **drag & drop** smart folder content (even 'Junk') onto e.g. 'User' or the desktop (see [External Drag & Drop](#)) to create folders containing real copies of those presets!

### Search History

Click on this folder to display the results of past searches (maximum 10). If you want the search results to be more permanent, right-click and select *Save Search*. To remove all searches, right-click on the 'Search History' folder and select *Clear*.

### Saved Searches

This folder contains searches that have been saved via right click from Search History. To remove individual entries, right-click and select *Delete*.

### Bank

These smart folders reference metadata about preset **origin** – the version of the factory library or the name of the soundsset with which the preset was installed. See [Patch Info](#). Banks are (or will be in time) predefined for factory presets as well as u-he soundssets.

You can even create your own custom banks: Drag & drop one or more presets onto the 'Bank' folder, then enter a suitable bank name into the dialogue box.

To remove Bank attributes from a selection of presets, either drag & drop them onto the 'no Bank' folder you will see at the bottom of the Bank list, or right-click on the Bank and select *Remove Presets from Bank*. Empty Banks will disappear.

### Favourites

8 smart folders, one for each Favourite colour. See [Presets context menu](#). Presets dropped onto a 'Favourites' folder will be marked accordingly. Only one Favourite colour/number can be set per preset. Favourites can be imported / exported - see [External Drag & Drop](#) below.

You can clear the Favourite status from all presets of one particular colour / index by right-clicking on the 'Favourite' folder and selecting *Remove All Favourite (n) Marks*.

Note: As presets are referenced by name as well as relative location they will not retain their Favourite (or Junk) status if moved using Finder / Explorer functions.

### Junk

A smart folder pointing to all 'junked' presets – see [Presets context menu](#). Dragged and dropped onto this folder, presets will disappear from the rest of the browser unless made visible (see *Show Junk* in the presets context menu).

Junk marks can be removed globally by right-clicking on the 'Junk' folder and selecting *Remove All Junk Marks*. If hidden, all junked presets will reappear in the browser.

### Tags

Smart folders for each Category/Subcategory, Features and Character tag. Presets dropped onto these folders will adopt the corresponding tag. Presets dropped onto the *Untagged* folder will have all Category, Features and Character tags removed.

## Author

Smart folders for each Author. Tip: Instead of signing each of your creations, you could sign just one of them, select them all and drag onto Author/*\*YOU\**/. This process cannot be undone, so to avoid setting wrong authorship please use this feature with caution! Right click on an author to rename globally.

## Directory context menu

Right-clicking on any folder within *Local* or *User* will open this menu:

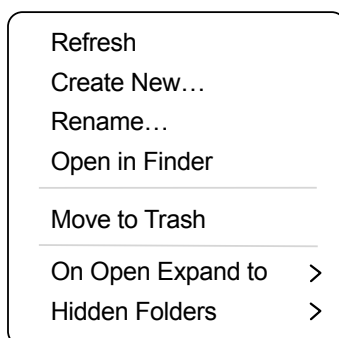

Note that this menu is dynamic: Some smart folders offer extra options e.g. 'Save Search'.

### Refresh

Update the browser contents, which is necessary for Windows users after altering any files in Explorer.

### Create New...

Insert an empty subdirectory.

### Rename...

Edit the folder name.

### Open in Finder / Explorer

Open a system window for the currently selected folder. Hold down *option* (Mac) or *ctrl* (Windows) to switch this to *Show in Finder / Explorer*, which highlights the folder instead of opening it.

### Move to Trash / Recycle Bin

Moves the selected folder to the system trash. If you right click on the *Junk* folder, this entry will be replaced by 'Remove All Junk Marks'. If you right click on a *Bank* smart folder, it will be replaced by 'Remove Presets from Bank' (see [Smart Folders](#) above)

### On Open Expand to

These options determine how deeply the browser will open subdirectories whenever the GUI is (re)opened or the refresh function is called. The first option, *none*, collapses all folders, while the final option *all levels* reveals all nested folders.

### Hidden Folders

Select smart folders you don't wish to appear in the directory: *Search History*, *Saved Searches*, *Bank*, *Favourites*, *Junk*, *Tags*, *Author*, *Duplicate Names*.

## Presets Panel

The central, unlabelled area of the browser is where you click to load presets...

### Presets context menu

Right-click to open a menu of options and functions that can be applied to presets:

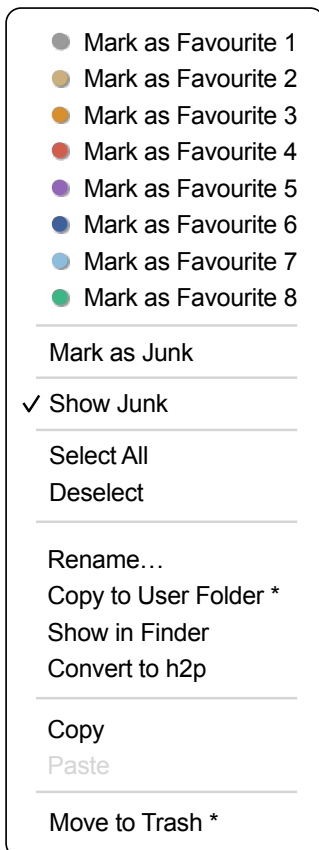

#### Mark as Favourite

Choose one of 8 'favourite' numbers / colours. The selected option will be replaced with *Unmark as Favourite*.

#### Mark as Junk / Show Junk

Instead of deleting unloved presets, you can mark them as 'junk' so they disappear from the browser. Activate *Show Junk* to display junked files, marked with a STOP symbol.

#### Select All, Deselect

See 'Multiple selection' on the next page.

#### Rename...

You can change the names of presets using this function. Note that only the most recently selected preset can be renamed i.e. you can't rename multiple files at once.

#### Copy to User Folder / Duplicate

The function here depends on the status of the *Save Presets To* preference as well as on the location of the source preset(s) i.e. whether they are in *Local* or *User*. Selected presets are copied with a number appended to the name, which is incremented so that presets cannot be overwritten by mistake. Saving under the same name offers you the option of renaming the original as a backup with the extension *.bak*. Although saved in the same location, *.bak* files do not appear in ACE's browser.

### Show in Finder / Explorer

Opens a system window for the right-clicked file. In smart folders only, holding down an *option* key (Mac) or *ctrl* key (Windows) replaces this entry with *Show in Browser*, which shows the **currently selected** file in its original location in ACE's browser.

### Convert to Native / h2p / h2p extended

Converts presets into the format previously selected via right-click on the [SAVE] button.

### Copy / Paste

Clipboard functions. Individual or multiple presets can be copied / pasted, even between ACE's browser and system windows (Finder, Explorer).

### Move to Trash / Recycle Bin

Moves presets to the system trash.

## Restore

While in the browser you can audition as many presets as you like in any folders without losing the one that was previously loaded: Clicking on the [Restore] button at the top left of the Presets panel will always get you back to where you started.

## Scan / Ready

In the top right of the presets panel is a dark rectangle normally labelled 'ready'. Upon *refresh* this turns into a progress indicator showing how much of the preset database has been refreshed. The process should only take a few seconds.

## Multiple selection

A block of adjacent presets can be selected via shift+click, and individual presets can be added to the selection via cmd+click (Mac) / alt+click (Windows). Presets can be moved to a different folder via drag & drop (see below). To deselect, either click on an unselected preset or choose deselect from the context menu.

## Drag & Drop

---

### Internal

You can drag and drop single or multiple files from the preset panel onto any folders in the directory panel. Files dragged onto regular folders will be moved unless you hold down option/alt (Mac) or ctrl (Windows), in which case they will be copied instead. Files dropped onto smart folders will adopt the attribute of that folder: For instance, you can set e.g. the Author or Favourite status of several presets at once.

### External

To manage your preset library externally you can drag presets and folders between ACE's browser and your desktop (or any system window).

On the Mac most Finder operations will automatically update the browser. Updating might not be immediate when using multiple formats or multiple host applications, but all it usually takes is a click on the GUI or in the directory tree (sets focus to the clicked instance of ACE). On Windows systems, a manual *Refresh* (see Directory Context Menu) will be required before changes to the contents of the browser appear.

### Exporting smart folders

Drag a smart folder onto e.g. your desktop to create a folder containing those presets. For instance, an entry in the Search History, one of the Favourites, the 'Drums' category (includes sub-folders!), all presets with the 'duo' feature, or an Author...

### Exporting favourite / Junk status

You can export Favourites, either all at once or individually. Shift+click and drag the 'Favourites' folder onto the desktop to create a file called *Favourites.uhe-fav*.

Similar for sub-folders: If you shift+click and drag e.g. 'Favourites 5', this will create a file called *Favourite 5.uhe-fav*. Such files can be imported into ACE's browser on a different computer (for instance), via drag & drop onto or anywhere within the Favourites folder.

Note: Importing *.uhe-fav* files from another computer will only work 100% correctly if all preset names and locations are identical on both computers!

## Patch Info

---

The panel to the right displays information about the selected patch:

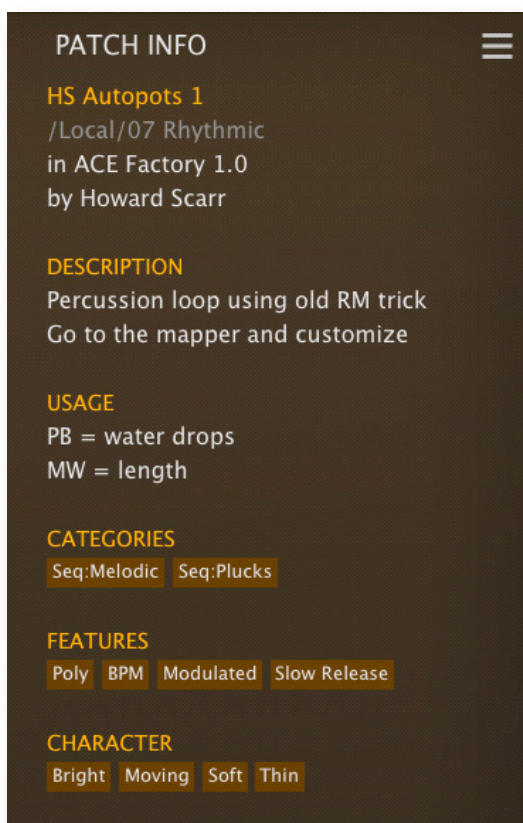

If you can't see this panel, click on the triple bar [≡] button and tick *Show Preset Info*.

- ✓ Show Preset Info
- ✓ Show Tags in Preset Info

DESCRIPTION and USAGE text can be entered into the dialog box which appears whenever you save a patch.

CATEGORIES, FEATURES and CHARACTER list the tags that are set for the current preset (see [Preset Tagging](#) below). You can even remove or add tags directly here in the Patch Info (see [Tagging via PATCH INFO](#)).

## Installing Soundsets

---

Any soundsets we distribute ourselves will be available as *.uhe-soundset* files. Third parties are also encouraged to use this package format for their own commercial soundsets – for details please contact our [support](#) team.

### Standard Method

To install, drag & drop the *.uhe-soundset* file into ACE – anywhere should work. The soundset will appear in the ‘User’ folder. If a soundset of the same name already exists in that location, any modified files will be backed up and the location of the backup file displayed.

### Alternative Method

Soundsets in *.uhe-soundset* format can also be installed by clicking on the u-he badge, selecting *Install Soundset...* from the menu and navigating to the *.uhe-soundset* file. This option is especially useful for Linux, as the browser version for that platform does not support drag & drop.

### Regular Folders

Folders containing ACE presets can be manually copied or moved into the ‘User’ folder. You might have to refresh the browser (see [Directory context menu](#)) before they appear there. A refresh is generally necessary in Windows but not in macOS.

Note: As *.uhe-soundset* files are really ZIP-compressed folders, you can rename them i.e. replace the file extension with ‘zip’, then extract the presets and documentation.

## Preset Tagging

“Tags” are elements of metadata, information that you can add to presets so that they can be found according to certain attributes. Read this carefully:

Tags are updated automatically – clicking on the [SAVE] button isn’t required! The main advantage is that presets don’t have to be saved every time you edit a tag. The main caveat is that **you should only edit tags after saving your preset**.

For instance, if you decide to edit tags while creating a 2nd version of an existing preset, please remember that you are actually changing the tags in the original preset!

### The Tagging Window

Right-click on the [SAVE] button and select *Tag this Patch*:

#### CATEGORY

Bass
Pads
Leads
Keys
FX
Drums
<b>Seq</b>
Other

Basslines
Dist+LoFi
Drum Loops
Effects
Layered
<b>Melodic</b>
Plucks
Pulsating

#### FEATURES

Mono
<b>Poly</b>
Duo
Chord
<b>BPM</b>
OscSync
RingMod
CrossMod
Dry
<b>Modulated</b>
Percussive
Soft Attack
<b>Slow Release</b>
Glide
MPE

#### CHARACTER

<b>Bright</b>	Dark
Constant	<b>Moving</b>
Clean	Dirty
<b>Soft</b>	Aggressive
Phat	<b>Thin</b>
Natural	Synthetic

CATEGORY describes a preset by analogy to instrument types or classic synth genres. Each one has its own set of subcategories. FEATURES are technical classifications, and CHARACTER tags are pairs of opposites from which you can choose only one.

### Tagging via PATCH INFO

In the PATCH INFO panel, right-click on CATEGORY, FEATURES or CHARACTER and select / unselect tags from the menu. If you right-click on an existing tag, the first option in the menu becomes *Remove Tag...*

The function *Create Search from Tags* finds all patches with the exact same set of tags.

### Tagging via smart folder

You can tag presets by drag & drop onto one of the ‘Tags’ smart folders. To remove all tags, drag presets onto the ‘[no Tags]’ smart folder.

## Search by Tags

Click on the TAGS tab to open this view. The buttons here let you set up search criteria according to existing tags with just a few mouse clicks. Results appear in the 'Search History' smart folder.

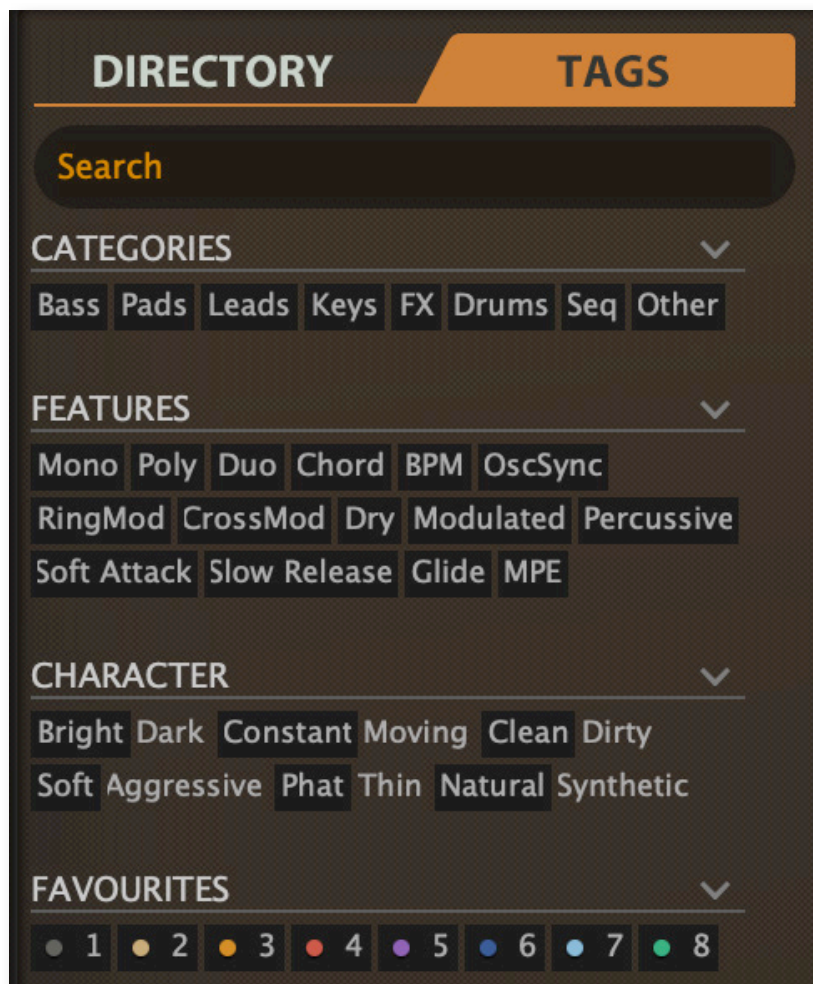

Below the Search field are four sets of buttons. The first three correspond to the tags in the tagging window (see the previous page), while the bottom row lets you find any presets you have tagged as *Favourites*. Clicking on the [^] icon to the right of each heading hides the options for that set of tags.

## Categories and Subcategories

Each Category has its own set of subcategories. Not selecting any subcategory here means “show me presets tagged with any subcategory”. Click on [Leads]...

You can select multiple categories without specifying any subcategory if you hold cmd (Mac) or alt (Windows) while clicking on the category. Try that with the [Keys] button.

Selecting the subcategory with the same name as the category means “show me presets tagged without a subcategory”. You will not find any in the factory presets.

Completed category+subcategory tags appear below the subcategories as buttons with ‘off’ switches [X] so you can add other main categories by simply clicking on them.

## Features, Character and Favourites

Unlike multiple Category tags, which expand the search, selecting these types restrict the search. Let's find all thin sounding presets with a slow release:

Click on the TAGS tab. If any Categories are highlighted, click on them. Then select FEATURES = [Slow Release] and CHARACTER = [Thin].

### Summary / Recap

In the DIRECTORY panel, specify a search path via double-click. In the TAGS panel, select category tags. Add others if required to extend the search, but remember to hold down cmd (Mac) or alt (Windows) if you want to retain category tags that don't specify a subcategory. Select Features, Character and/or Favourites tags to refine the search. Exit any search path by clicking on the [X] to the right. You'll soon get the hang of it!

## Search by Text

The Search field lets you find presets according to a string of characters i.e. text. Here's an easy example: If you remember that the preset you're looking for has the word "clock" in its name or description, enter "clock" into the Search field and hit Return.

The search normally looks into the preset name, author, DESCRIPTION and USAGE (see the PRESET INFO panel). Searches are not case-sensitive, and quotes are not required unless you need to include spaces.

To restrict the search to a particular path, for instance Local/04 Pads, double click on a folder. This path will appear beneath the Search field instead of the preset folders, and you will only see smart folders (unless the specified path contains sub-folders).

See the image below. The [^] button to the left moves the Search path up one level, in this case to /Local. The [X] button to the right sets the search path to Local as well as User (i.e. all ACE presets), and the preset folders become visible again.

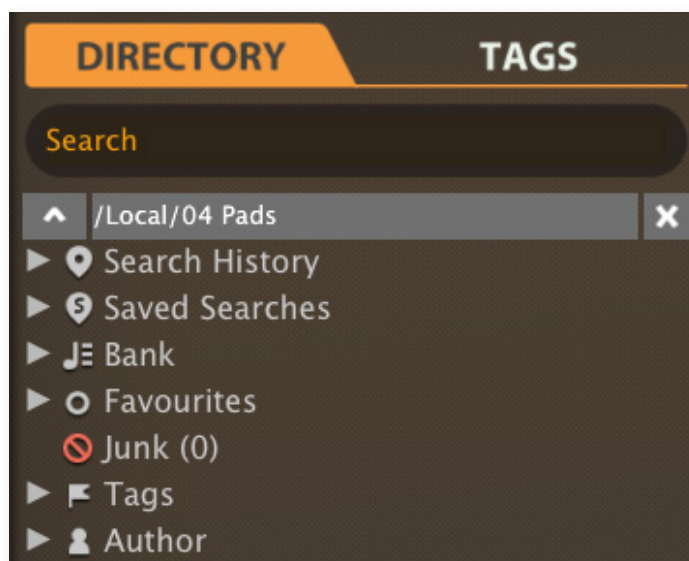

Try a text search: Enter three or four letters then hit Return. For instance, *star* will find all files containing the text string *star* (e.g. mustard or starters). Entering "*star wars*" (with the quotes) would find e.g. Battlestar Warship, if such existed in the presets.

## Syntax

### Scope

You can limit the scope of the search to just the preset name or specific parts of PRESET INFO by using *name* (preset name), *author*, *desc* (description) or *use* (usage) followed by a colon. For instance, *author:the* finds all presets by sound designers whose author names contain 'the'. Similarly, *desc:space* will find all presets with the word 'space' in the description.

### Logical Operators

AND requires that presets contain both words. It can be written explicitly if you prefer, but is not necessary. For example, *star AND wars* (or simply *star wars*) will find presets that contain both 'star' and 'wars'.

OR means that presets can contain just one of the words or both. For example, *star OR wars* will find presets that contain 'star' as well as presets that contain 'wars'.

NOT excludes presets containing the word. To find all presets that contain 'star' but don't contain 'wars', enter *star NOT wars*.

### Including Tags

Regular tags can also be entered into the search field if preceded with a '#'. For example, *name:"hs " #bass:\** will find all presets with "hs " in the name that are tagged as Bass with any or no subcategory. The colon separates category and subcategory, and the star (\*) means "any subcategory, even none". Between multiple tags of the same type is an implicit OR, while between different types is an implicit AND.

Tags must appear **after** any text items, as in the last example here...

### More Examples

Copy the *italic* text, paste it into the search field and hit Return.

<i>desc:classic</i>	presets with the word "classic" in the description
<i>author:bigt</i>	presets by BigTone
<i>use:"at =" author:how</i>	aftertouch-controlled presets by Howard
<i>tasm OR exo #pads:strings</i>	strings by either Tasmodia or eXode

# Modules

## Oscillators (common parameters)

All oscillators, VCOs as well as LFOs, include the following parameters:

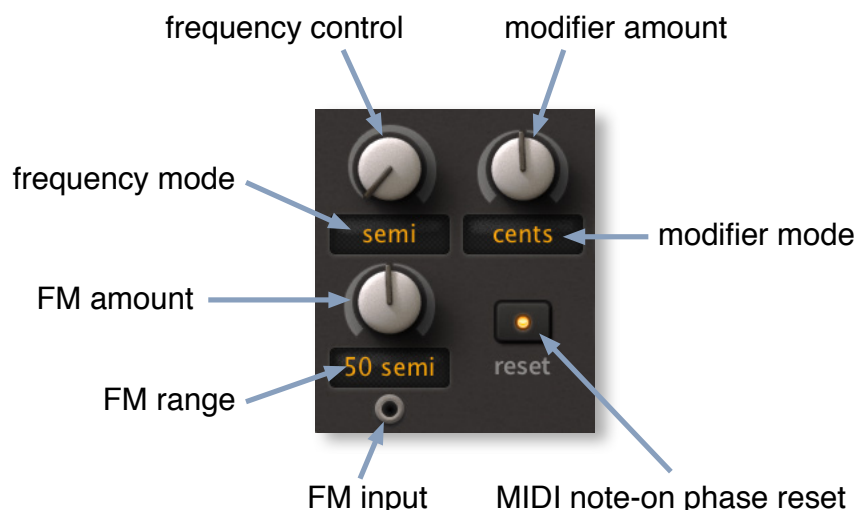

### frequency

The frequency control has a range of 0.00 to 24.00. The frequency modes are:

*semi*.....maximum 24 semitones above the current pitch.

*partial*.....the first 24 overtones – octaves are at 1.00, 3.00, 7.00, 15.00

*subharm*.....the first 24 subharmonics – look up "Trautonium" on the web

*Hertz*.....0Hz to 24Hz. 0.00Hz is no signal because DC components are removed

*sync*.....sync to song tempo, divider – 1.0 is a whole note, 4.0 a quarter note etc.

Note: As VCO output is DC-blocked, the shape of a VCO set to *Hertz* or *sync* (i.e. used as an LFO) might not be what you expected.

### modifier

The modifier control range is -50.00 to +50.00 (bipolar). The modifier modes are:

*cents*.....detunes the oscillator by +/- 100 cents i.e. 1 semitone

*5 Hz*.....detunes the oscillator by +/- 5 Hertz

*beats*.....detune in sync with song tempo. +4.00 = one extra cycle per quarter note

*mtply*.....frequency is multiplied (from 0 to 50) or divided (from 1/1 at -1.00 to 1/50th)

### FM amount

The amount of frequency modulation from the FM input. Available FM ranges are:

*cents*.....+/- 100 cent i.e. 1 semitone

*5 semi*.....+/- 5 semitones

*50 semi*.....+/- 50 semitones

## reset

The oscillators in analogue synths tend to run *continuously* i.e. they never stop. Those in digital synths are generally not computed until each note is played. This means that they either start at a random phase (most similar to analogue) or at the same phase each time you play a new note, which results in a more consistent attack.

*off*.....random phase

*on*.....same phase

## VCO1

See [Oscillators](#) above for parameters common to all oscillators (VCOs as well as LFOs).

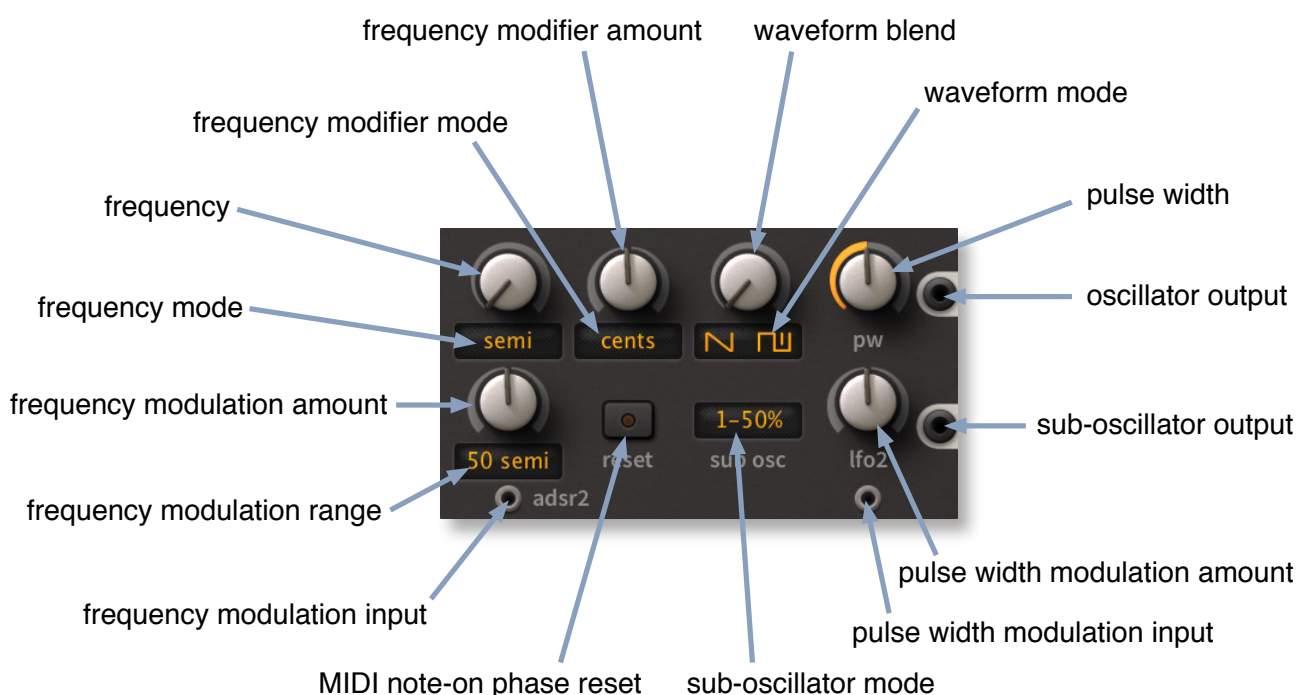

## waveform blend / mode

Crossfade between *saw* and *pulse* or *peak* and *triangle*, depending on the mode.

## sub-oscillator

VCO1 includes a sub-oscillator with its own separate output socket. Click on the **sub-osc** switch to select a 50% pulse wave (perfect square) pitched 1 or 2 octaves below the main oscillator, or a 75% pulse wave 2 octaves below.

## pulse width (pw)

The width of the pulse wave is variable from 0% to 100%. Any signal can be used for pulse width modulation (PWM), even an audio oscillator. The default source is LFO2.

## VCO2

See [page 23](#) for parameters common to all oscillators (VCOs as well as LFOs).

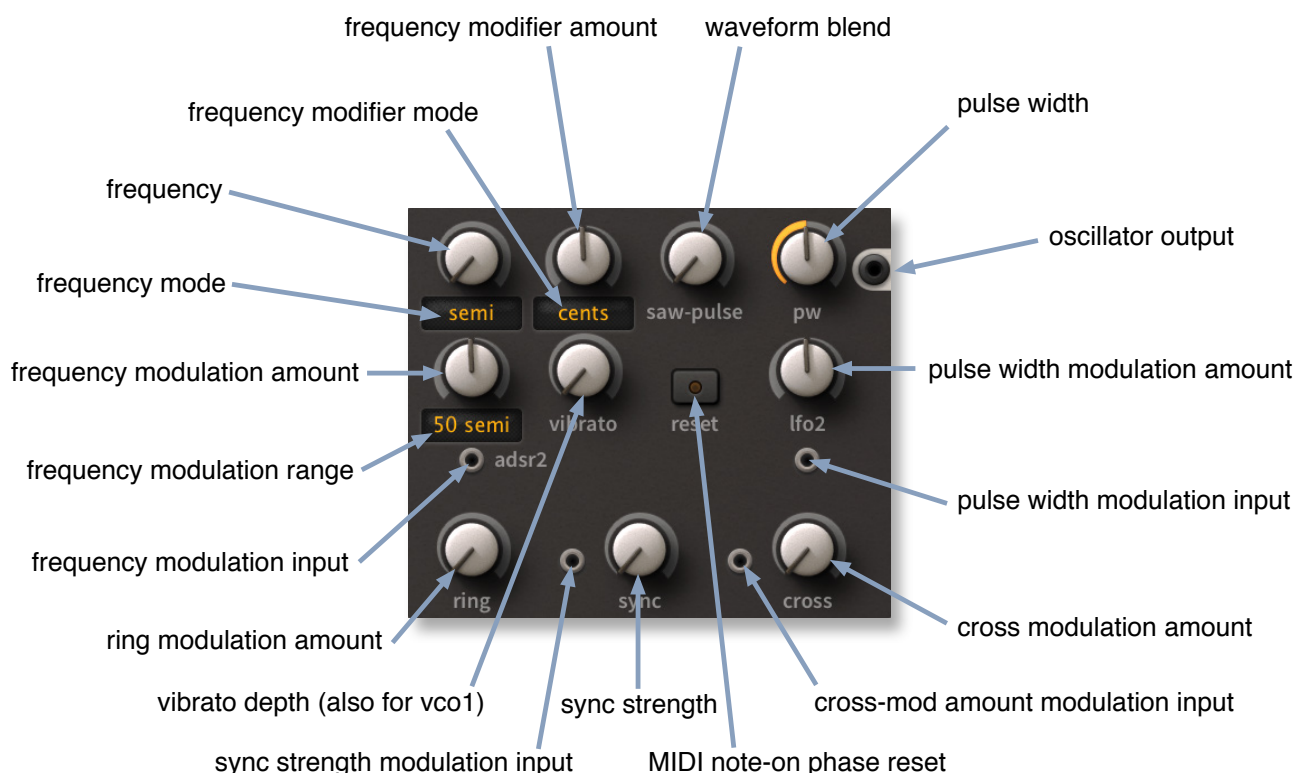

### waveform blend

Crossfades between saw and pulse.

### pulse width (pw)

The width of the pulse wave is variable from 0% to 100%. Any signal can be used for pulse width modulation (PWM), even an audio oscillator. The default source is LFO2

### vibrato

Frequency modulation for both VCOs from LFO1, hardwired. Although it also affects VCO1, placing this knob in the VCO2 panel was a necessary compromise.

### ring

Ring modulation. Cross-fades between pure VCO2 and VCO1 \* VCO2 ring modulation. Depending on the waveform and frequency interval, ring modulation can create metallic sounds, nasal sounds... or even rhythms if VCO1 is set to e.g. *sync* mode.

## sync

The phase of VCO2 is not only reset when it completes its normal cycle, but also whenever VCO1 completes a cycle (turn *sync* up to maximum for the standard ‘hard sync’). The pitch of VCO2 is normally set higher than VCO1, and VCO2 is often modulated by an envelope or LFO to sweep the effect. Hard sync can deliver sounds that are very rich in harmonics without losing the fundamental pitch (of VCO1).

Set lower values for a special kind of ‘soft sync’: Again, the phase of VCO2 is reset by VCO1 – but not to 0°! The phase of VCO2 moves by a proportion of its current value (e.g. 50%), which lets you create pure-interval overtones. Experiment with the sync knob and the interval between the two oscillators – you should quickly discover some very interesting overtones and quasi-chaotic effects.

Connecting a cable to the sync modulation socket effectively replaces a +5V default modulator. Tip: Try patching velocity or an envelope into the sync input.

## cross

Short for “cross modulation”. In ACE this means analogue FM (frequency modulation), with VCO1 modulating VCO2. Connecting a cable to the cross modulation socket effectively replaces a +5V default modulator.

## LFO1

See [page 23](#) for parameters common to all oscillators (VCOs as well as LFOs).

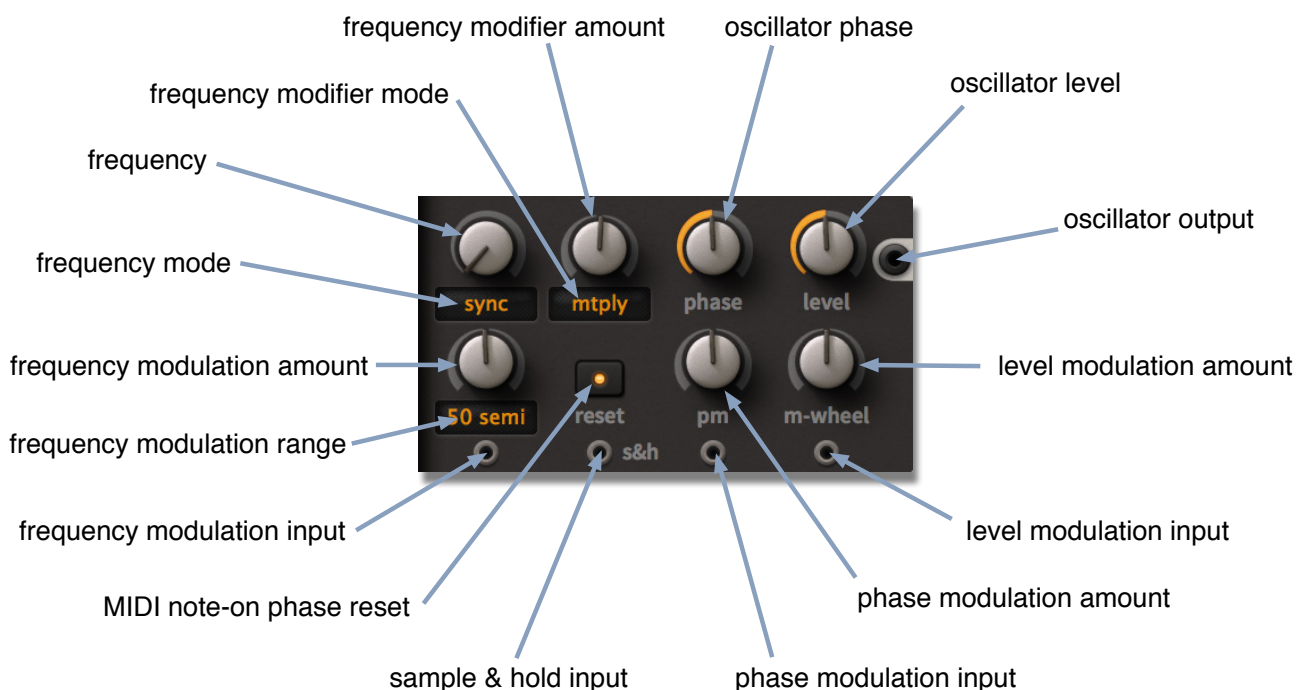

LFO1 normally generates a pure sine wave. The LFO1 specialities are vibrato, phase modulation i.e. classic FM, sample & hold... and waveshaping!

## phase

The *phase* knob adjusts the phase position i.e. where in its cycle the waveform will start whenever the LFO is *reset* (see below). LFO1 has a *phase modulation* input: Connect another oscillator here for classic FM sounds. Of course the phase modulation source can be LFO1 itself, which skews the sine wave towards something close to a sawtooth. Note: The phase knob has a very different role in *sample & hold* mode – see *s&h* below.

## level

LFO1 output level. Both LFOs have amplitude modulation inputs, and the default source for LFO1 is the modulation wheel (*m-wheel*) for instant “vibrato via mod wheel”.

## reset

This switch determines whether the LFO phase is reset by MIDI note-on events. Note: If the frequency mode is *sync*, LFOs are also reset in sync with the host program.

*free* .....not reset, runs continuously (“monophonic”)

*gate* .....per-voice reset whenever a note is played (“polyphonic”)

## s&h (sample & hold)

If anything is connected to the *s&h* input, LFO1 switches into sample & hold mode, and samples the input at its own “clock speed”. For vintage random effects, connect noise here. In *s&h* mode the *phase* knob becomes a lag processor, smoothing out jumps between successive values. At very high LFO1 rates, the phase parameter acts like the cutoff control of a lowpass filter (but in the opposite direction). If you find LFO1 strangely silent in *s&h* mode, set its *phase* closer to zero.

## a few LFO1 tricks

**random modulation:** Connect white noise (“white”) to the *s&h* input and use LFO1 to modulate e.g. VCO frequency or VCF cutoff. Adjust LFO phase.

**sample rate reduction** effects: [Initialize](#) the patch, drag a cable from the LFO1 output directly to one of the VCAs and turn the other VCA all the way down. Next, connect an audio signal (e.g. VCO1) to LFO1’s *s&h* input. Set the LFO1 frequency mode to *semi* and the LFO1 phase to around zero (otherwise you won’t hear anything). Try various *mtply* values between 1.50 and 25.00. LFO1 adopts the pitch of the sampled oscillator and delivers a much rougher version.

**waveshaping:** Although the VCFs can deliver lots of distortion, especially connected in series, you can also use LFO1 as a waveshaper: [Initialize](#) the patch, drag a cable from the LFO1 output directly to one of the VCAs and turn the other VCA all the way down. Set *semi* with a multiplication factor (*mtply*) of 0.00 to freeze the LFO. Set the phase to 0.00 (LFO1 always resets to 0° now).

Then patch the signal you want to process (e.g. VCO1) into LFO1’s phase modulation input. Turn *pm* up – there’s your *sine waveshaper*! Adjust the phase to make the effect asymmetrical. By the way, the processed signal doesn’t have to be audio: you can use this method to ‘waveshape’ any signal you like e.g. an envelope.

## LFO2

See [page 23](#) for parameters common to all oscillators (VCOs as well as LFOs).

Instead of phase modulation and s&h, LFO2 offers a much wider variety of waveforms than LFO1... which makes LFO2 easy to use as a third audio oscillator.

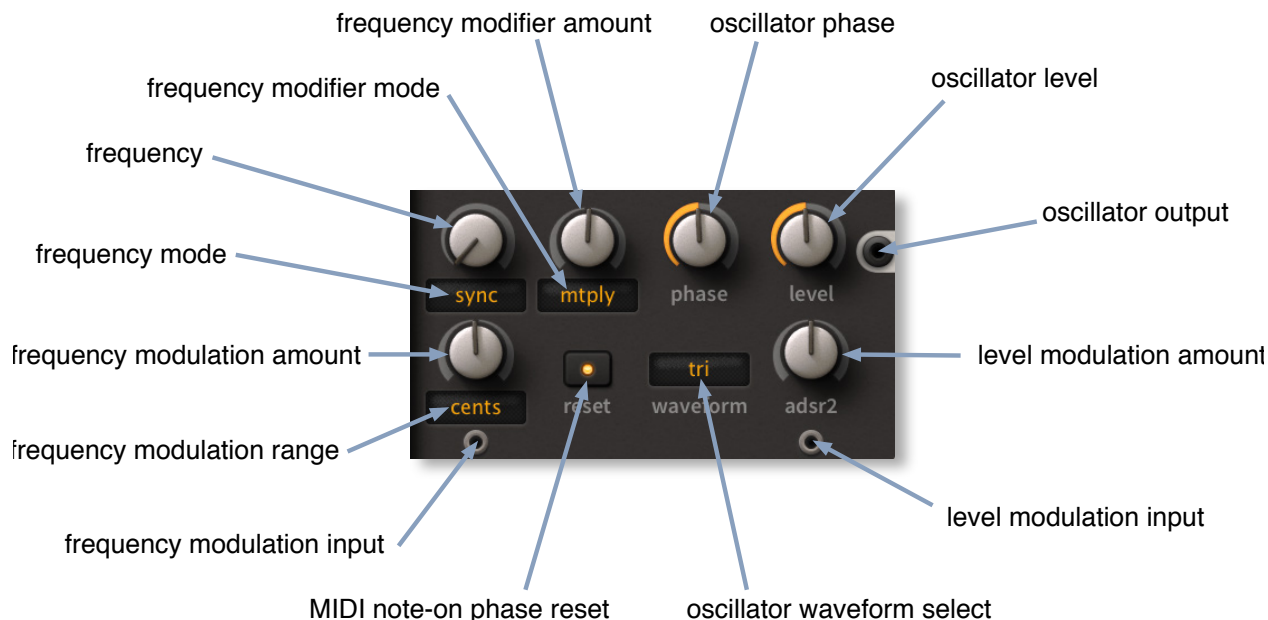

### phase

The phase knob adjusts the phase position i.e. where in its cycle the waveform will start whenever the LFO is *reset* (see below).

### level

LFO2 output level. Both LFOs have level/amplitude modulation (AM) inputs and associated amount controls, and the default source for LFO2 is ADSR2.

### reset

This switch determines whether the LFO phase is reset by MIDI note-on events. Note: If the frequency mode is *sync*, LFOs are also reset in sync with the host program.

*free* .....not reset, runs continuously (monophonic)

*gate* .....per-voice reset whenever a note is played (polyphonic)

### waveform

The first four LFO2 waveforms are standards, but the last in the list is very special:

*sine* .....sine wave, pure

*tri* .....triangle wave, pure

*saw* .....sawtooth wave, bright

*square* .....square wave, hollow

*tap map* .....the data in the [Mapping Generator](#) interpreted as a waveform. Note that setting *tap map* does not stop the mapping generator from being used as a modulation source at the same time!

## MIX

In the middle of the window is a mixer that serves as the default link between the main sound generators and the sound processing in ACE. The MIX module also includes amplitude modulation inputs. Note that its output is sent to VCF1 by default.

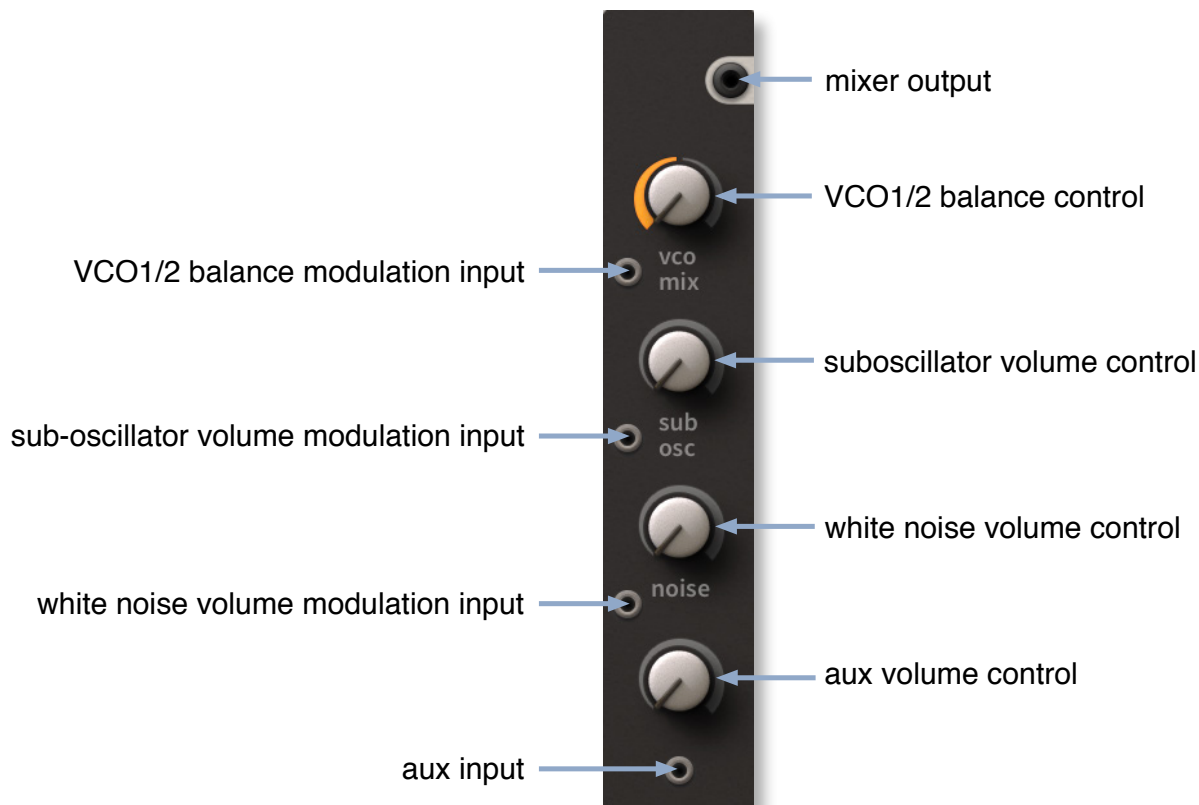

### vco mix

The upper knob controls the relative levels between VCO1 and VCO2. The central position (0.00) is a 50-50 mix of both VCOs.

Of course the balance modulation input will also accept audio rate signals: remember *any cable everywhere!* Tip: For bipolar modulation sources (LFO, VCO) set the mix knob to the centre, for unipolar sources (e.g. mod wheel, ramp) set it to maximum.

### sub osc

VCO1's sub-oscillator.

### noise

White noise. Tip: A small amount of white noise mixed into a pad patch can give the filters and chorus more frequencies to work with, making the sound fuller.

### aux

The unlabelled knob is the level control for the auxiliary input at the bottom of the mixer. Connect anything you like here: pink noise, a pitched LFO – or even VCF1 for instant *filter feedback*.

## VCF

ACE's two filters are almost (but not quite) identical. The screenshot here shows VCF2, with its cutoff mode selector and bipolar cutoff knob...

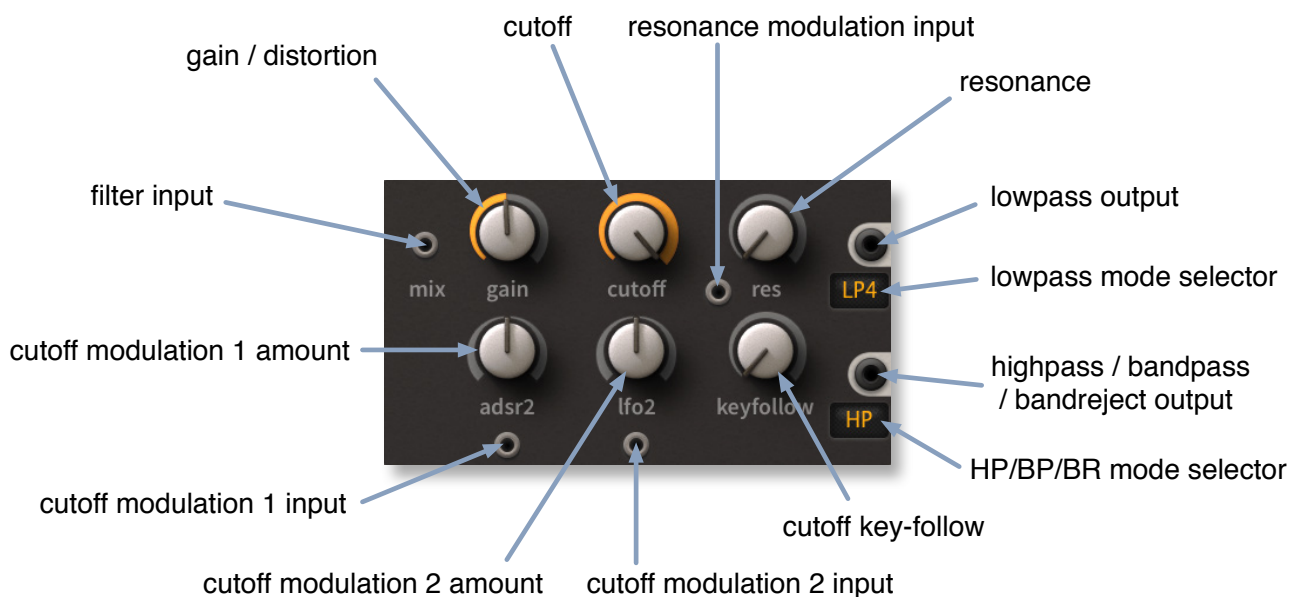

The filters in ACE have several properties normally associated with analogue hardware only. For instance, they can easily be overdriven without sounding harsh. Unlike classic hardware filters, strong overdrive in ACE won't necessarily kill the resonance. Just turn it up – there's plenty of headroom there.

Especially around the self-oscillation threshold, where the resonance appears to struggle with the oscillators for control over pitch, there are surprising opportunities for organic/chaotic sound design. Depending on the input signal and its gain, it can even sound as if the input is actually *modulating* cutoff. Experimentation is the name of the game here!

The underlying cascade filter architecture gives you different filter types in parallel, just like hardware multimode filters. In ACE however, *all* types are capable of resonance and even self-oscillation.

Tip: if a single filter still sounds too tame for your evil purposes, you could try patching the filters in series i.e. one after the other, and increasing the gain of the second filter. This is a great way to make very bold, biting sounds similar to hardware filter units.

### gain

VCF input level (negative values) and overdrive (positive values).

Tip: for typical screaming distortion (TB303 etc.), use another VCF in series. Set it to LP1 mode, with maximum cutoff and very high gain.

## cutoff

**VCF1:** Cutoff frequency is measured in semitones from 0.00 to 150.00 (12 octaves) and the modulation range is +/-150 semitones. Note: the input / knob at the bottom left of the VCF panel also modulates cutoff, *not* gain.

**VCF2:** Instead of a simple unipolar cutoff, VCF2 has 3 modes with bipolar *cutoff* control:

*cutoff*.....like VCF1 but bipolar (you can also set negative values)

*offset*.....VCF2 cutoff follows VCF1, including any modulation, with a bipolar offset.

This means that VCF2 cutoff can be modulated directly by up to four sources, two within the VCF2 panel and two adopted from VCF1

*spread* .....like offset, but also affects VCF1 cutoff in the opposite direction

## keyfollow

Keyfollow causes cutoff to follow the MIDI note. If keyfollow is set to maximum, cutoff follows MIDI notes 100%, like the VCOs.

## resonance

The **res** range is 0.00 to 100.00. Although self-oscillation can start around 50.00, the actual amount of resonance depends on the level of the input signal (see **gain** above), so a generous range was necessary here. Resonance can be modulated by connecting a signal to the socket to the left of the *res* label (effectively replacing a +5V default).

## outputs

Each filter has two parallel outputs. The upper one offers four grades of lowpass...

LP1< .....6dB/octave (1-pole lowpass)

LP2 .....12dB/octave (2-pole lowpass)

LP3 .....18dB/octave (3-pole lowpass)

LP4 .....24dB/octave (4-pole lowpass)

...and the lower one has three other types:

HP.....high pass

BP.....band pass

BR.....band reject (notch)

## ADSR

What would a synthesizer be without envelopes to control the ebb and flow of levels? ACE has two identical envelope generators:

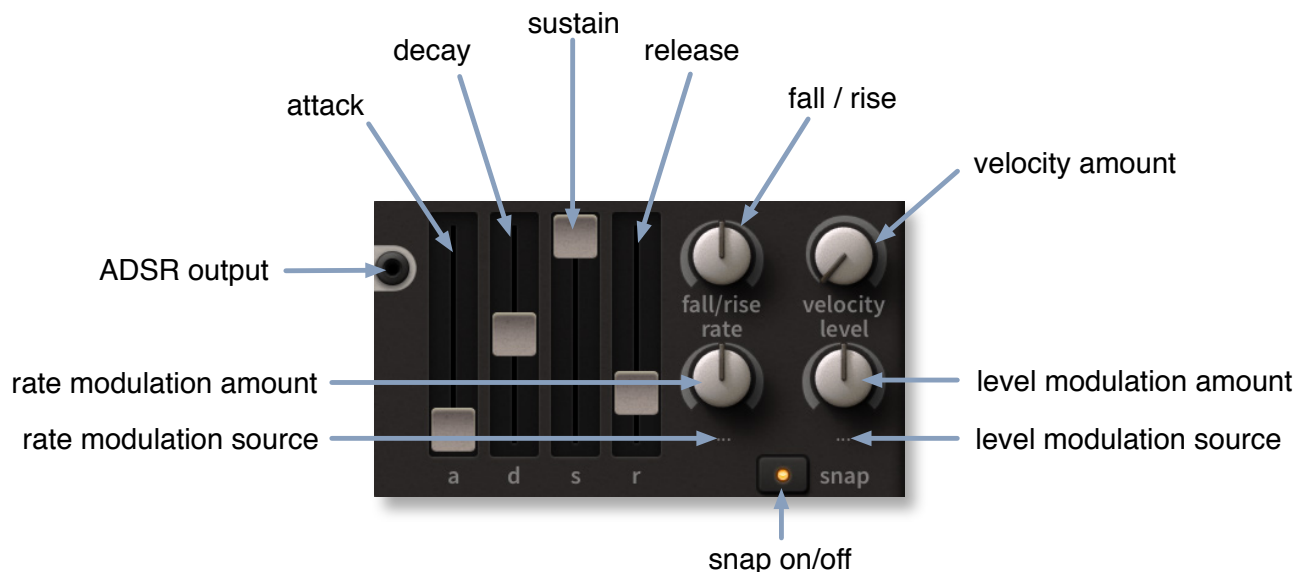

### a, d, s, r

Like the vast majority of synthesizers, the main envelope parameters are **A**ttack time, **D**ecay time, **S**ustain level and **R**elease time. But ACE also has a few extras...

### fall/rise

Firstly, the bipolar **fall/rise** knob causes the normally flat sustain to fall or rise at a defined rate. There's a parameter in the Tweak page called [fall/rise range](#) that limits how far towards zero / maximum the sustain level will fall / rise.

### rate modulation (...)

The lower lefthand knob is user-definable (hence the '...' default label). This parameter lets you modulate the envelope rates (attack, decay and release). Right-click on the knob to select a modulation source. For instance, selecting KeyFollow and setting a negative value here will make higher notes shorter, simulating the characteristics of plucked or struck instruments.

### velocity amount (vel)

Envelope levels can be scaled via MIDI velocity (vel), as well as via a source selected by right-clicking on the lower righthand knob ("..." means none yet i.e. undefined).

### level modulation (...)

The lower righthand knob is user-definable (hence the '...' default label). Lets you modulate the overall ADSR level. Right-click on the knob to select a modulation source.

### snap

Activating this switch makes the decay and release more extreme, more "snappy" if the envelope stages are already relatively short.

## Ramp Generator

If you find that two envelopes and two LFOs aren't quite enough for a complex patch, you could take a look at the ramp generator – it can fill either of these roles quite well. The ramp is not a simple decay, it is a linear attack-hold-decay (AHD) envelope with an off time (similar to the *trapezoid* envelope peculiar to the classic EMS synthesizers).

**up** is the attack time

**hold** is how long it remains at maximum

**down** is the release time

**rest** is how long it remains at zero before repeating

Unlike standard envelopes, the ramp generator will stay at maximum for the period set by *hold*. If *rest* is set to maximum, the ramp is a one-shot envelope i.e it does not repeat.

Note: the Tweak page includes a parameter called [ramp clock](#) that sets the ramp segments to either seconds or one of two different sync values.

## Multiplex

The *multiples* you will find in most analogue modular systems are simple mix/split devices, often just four sockets bridged together. As most modular synthesizers have a very limited number of inputs and outputs per module, multiples are important – without them it would be impossible to modulate more than one parameter at a time from e.g. an envelope generator, or plug more than one or two audio sources into a filter.

The humble multiple underwent a serious redesign for ACE (and Bazille), finally emerging as something much more useful than a multiple: the **multiplex**:

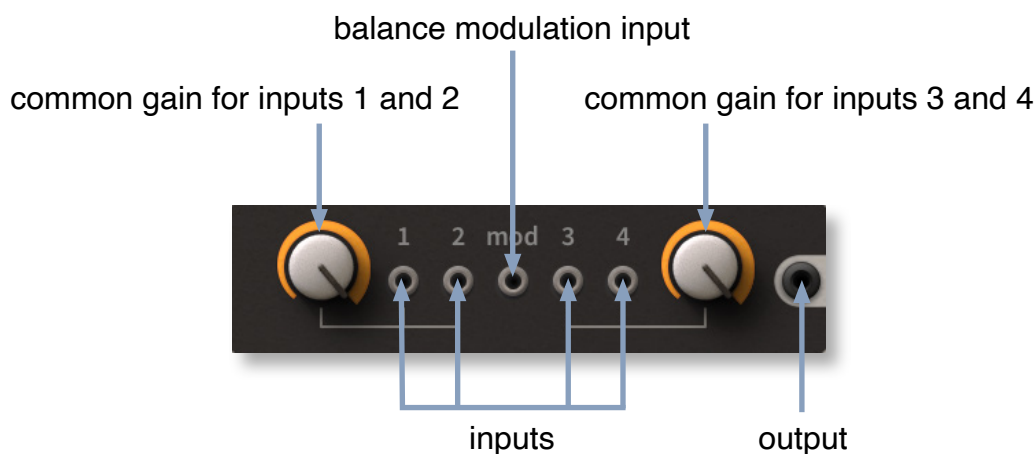

### example 1: simple mixing



In this example, four signals are connected to each of the inputs. The lefthand knob is around 60% while the righthand knob is at maximum, so the sum of the signals in inputs 1 and 2 is less than the sum of the signals in 3 and 4. You can mix up to 4 signals, arranged in pairs with a shared gain control for each pair.

## example 2: ring modulation (RM)



Here, the signal connected to input 1 is ring modulated (i.e. multiplied) with the signal in the modulation input. If you connect another cable to input 2, the sum of both inputs will be ring modulated with the *mod* signal.

Whenever a cable is connected to the *mod* input, the lefthand knob crossfades from the dry sum of inputs 1 and 2 to the ring modulated signal. In the above image, the lefthand knob is at around 60, meaning that the output includes some of the original input 1 signal. As inputs 3 and 4 are unused the value of the righthand knob is irrelevant.

As ring modulation is actually multiplication, the multiplex can be used to *scale* control signals from another source. For instance, if you connect an LFO to input 1 and velocity to the *mod* socket, you will get *LFO level x velocity* – the harder you play the note, the more LFO signal will appear at the output.

## example 3: amplitude modulation (AM)



Another classic effect: Amplitude modulation (AM) is like ring modulation except that, as well as the side bands, the output also contains the modulated original signal.

While RM could be written as  $y = a \times mod$ , AM is normally  $y = a \times (1 + mod)$ . However, AM in ACE's multiplex is defined as  $y = a \times (1 - mod)$ . There's a very good reason for this departure from the norm, as you will see shortly...

Amplitude modulation is achieved by using inputs 3 and/or 4 in conjunction with the *mod* input. Like in ring modulation, the righthand knob crossfades from only the original signal(s) to only the amplitude modulated signal.

Like in ring modulation, the level of a signal can be controlled via another, but in this case control is **inverted** – the 'minus' symbol in  $y = a \times (1 - mod)$ .

## example 4: unipolar crossfade



RM and AM can be used at the same time! In this example, the *mod* signal (green) controls the balance between inputs 1 and 3. If e.g. an envelope were connected to the *mod* input, that envelope would crossfade smoothly between inputs 1 and 3.

### example 5: bipolar crossfade



Using bipolar modulation signals for crossfading is less straightforward. To get 100% separation at extreme values you will need to set the lefthand knob to 50.00 and bridge the lefthand inputs to double the level.

### example 6: signal inversion



To invert a signal, connect it to the *mod* input of a multiplex, then +5v to input 3 or 4.

## VCA

---



All analogue synthesizers have at least one 'VCA' (Voltage Controlled Amplifier) at the end of the signal chain. ACE has two identical virtual VCAs, each with a pan control and pan modulation socket. However, the **default inputs signals** differ: For VCA1 this is VCF1 lowpass, while for VCA2 it is VCF2 lowpass.

The knobs in this section are fairly self-explanatory: **volume** and stereo **pan** position.

The selectors are for envelope control: ADSR1, ADSR2 or Gate. The latter is a simple on/off envelope which can be used to free up ADSR1 for other duties.

## Signal Sources

Along the bottom of the panel is a row of signal sources:

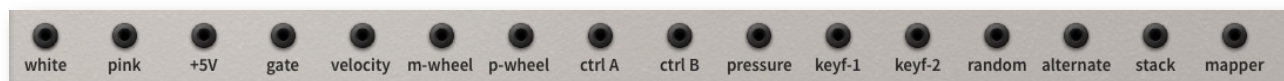

**white**.....white noise output (brighter, great for percussion sounds)

**pink**.....pink noise output (good for classic wind and wave effects)

**+5V**.....a constant "voltage" which can be used e.g. to create DC (direct current) offsets or to modulate parameters beyond their normal ranges

**gate**.....+1 while a note is being played, otherwise 0

**velocity**.....MIDI note velocity output

**m-wheel**.....modulation wheel (CC#01) output

**p-wheel**.....pitch bender output

**ctrl-a**.....breath control (CC#02) output by default, but assignable in [Preferences](#)

**ctrl-b**.....expression pedal (CC#11) output by default, but assignable in [Preferences](#)

**pressure**.....aftertouch output: both polyphonic and channel pressure are recognized

**keyf-1**.....note number. Unlike the dedicated filter 'keyfollow', keyf-1 pivots around E3 (MIDI note 64) so that lower notes can deliver negative values.

**keyf-2**.....same as keyf-1 but includes the glide2 offset (see below)

**random**.....a random value per note

**alternate**.....toggles between +1 and -1, per note

**stack**.....the stack index – for creating any kind of offsets between stacked voices (note: for pitch offsets, use the dedicated stacked voice tuning controls)

**mapper**.....the mapping generator output

# General Settings

The top left panel contains parameters that are not specific to individual modules:



## output

The knob at the top right of the panel is ACE's **master volume** control.

## MPE status

Activates [Multidimensional Polyphonic Expression](#) mode. See MIDI Specialities chapter.

## Polyphony and Quality

---

### mode

Determines the polyphony and how MIDI notes are interpreted.

*poly* .....polyphonic  
*mono* .....monophonic, retrigger  
*legato* .....monophonic, no retrigger  
*duo* .....duophonic

### voices

Only relevant for *poly* mode, this parameter sets the maximum number of notes that can be played before voice-stealing occurs.

*few* .....4 voices  
*medium* .....8 voices  
*many* .....16 voices

### quality

**draft, standard, good, accurate**

The quality switch is mostly for controlling CPU load, an important consideration in ACE. Tip: start with *good* and compare the sound with other quality settings. Depending on

modulation rates, filter distortion and/or whether the sound of high notes is important, *standard* or *draft* can be used without compromising the result.

## stack

The number of voices played in unison. Up to 8 voices can be stacked for a very powerful unison effect like a few classic polyphonic synths e.g the Oberheim OBXa. However, ACE can still be played polyphonically. This is not a "supersaw", it is true unison i.e. the entire voice is multiplied.

Of course this feature eats a lot of CPU power, but we think it is worth it. For instance, multiple filter distortion on one note is more lively than a single filter could possibly be.

Using the [Stacked Voice Tuning](#) knobs in the Tweak page, the 8 voices can be detuned within a range of +/- 24 semitones.

## Pitch Settings

---

### pb up / down

Separate pitchbend ranges, 0 to +/- 24 semitones, 36 (3 octaves) or 48 (4 octaves).

### drift

If *on*, voices are slightly detuned against each other for a fuller, more lively sound.

### transpose / tune

Transpose adjusts the overall pitch over a +/- 2 octave range.

Tune also adjusts the overall pitch over a +/- 100 cent range (+/- one semitone).

### glide controls

Glide or 'portamento' is a smooth pitch transition between consecutive notes. In ACE it also affects the 'Key Follow' modulator.

*glide* .....controls either the *time* or the *rate*, depending on the state of the *glide mode* switch (see below)

*glide2* .....offset relative to the glide value, applied to LFO2, VCO2 and VCF2 only. Careful use of this parameter can really bring static sounds to life!

*range* .....In classic polysynths, polyphonic portamento was seldom used except for special effects. In ACE, the range parameter can shift the initial position (where the glide starts) closer to the target note. This means that the glide can start "already half way there" for a more subtle effect.

Tip: for natural intonation effects, set the range to very low values.

*glide mode* .....*time*: the glide will take exactly the same time, however close together or far apart the notes are. *rate*: the glide is proportionally slower for notes that are further apart.

# Effects

The upper-right panel controls ACE's three post-VCA effects: Chorus, Delay and Tone...



## Chorus

Traditionally, chorus is a simple very fast delay periodically shortened and lengthened by a dedicated LFO. The pitch of the delayed signal rises and falls like the *Doppler Effect* you hear when a fast car (or the classic example: an ambulance) passes by.

Mixing the delayed signal with the original dry signal results in a warm comb-filter effect similar to slightly detuned oscillators. As the delays are under 50 milliseconds, they blend well with the dry signal i.e. they aren't perceived as individual echoes.

Chorus can be made richer by using more than one delay line with different modulation depths and LFO phases. Most of today's chorus units are stereo, using two delay lines fully panned apart. The one in ACE has four different models – 3 varieties of chorus (4 or 8 voices) plus a classic phaser:

### mode

**Chorus 1** is a 4-voice chorus with triangle LFO. Triangle modulation keeps the detuning effect fairly constant and therefore more subtle than Chorus 2....

**Chorus 2** is also 4-voice, but has a sine LFO for more dramatic movement.

**Chorus 3** is an 8-voice chorus for lush ensemble effects – of course without the high noise floor typical of the original hardware units.

**Phaser** is a classic phaser with a more subtle comb-filter effect than the chorus models. The phaser includes a variable feedback instead of the mix parameter. Higher feedback values result in a very dramatic resonant or metallic (due to atonal phase shifting) effect. Tip: Set the depth to minimum for strong tonal coloration but no movement.

One special feature of ACE's chorus is that the low bass content of the signal bypasses the effect, which helps preserve the body of the sound – adding chorus in other synthesizers usually means losing a lot of “oomph”.

## rate

Speed of the effect's own modulation LFOs

## mix

In all *chorus* modes, this knob controls the amount of delayed signal (0 to 50%), in *phaser* mode it controls the amount of resonance

## center

Nominal delay time before modulation, affects the overall **tone** of the effect

## depth

LFO modulation depth

## Delay

---

Delay is another traditional effect often used in for synthetic sounds. Unlike chorus, the delay times are long enough for repeats to be perceived as individual echoes.

The first delay units used magnetic tape while the next (solid state) generation was made of *bucket brigades* – a large number of capacitors each provided a short delay, which were arranged in series to produce a single long delay. Both techniques had major drawbacks, the most serious of which were noise and lack of synchronization capability. However, these units do have their own special charm, which is why digital emulations of tape and bucket brigade delays are still available, as hardware or plugin effects.

In the '80s, when the price of memory dropped considerably, digital delays quickly displaced analogue – they were cheaper to manufacture, they were more precise and the sound quality was deemed better. However, most people in the 1980s were convinced that the early digital synths sounded much better than analogue... how times change!

ACE's delay is a simple low-noise digital type with two taps and synchronized timing...

## times

Click on the button to select delay times/patterns:

*off, 8th + 8th, 8th groove, 8th dotted, 4th + 4th, 4th groove, 4th dotted, slap*

## mix

Dry/wet mix for the delay.

## spread

The **spread** knob controls stereo width: at 100 the taps are panned 100% to the left and right channels, at 0.00 both taps are in the centre (mono), and at -100 the left and right taps are swapped.

## feedback

The amount of delayed signal fed back into the delay input, which ultimately affects the number of echoes. As the delay is synchronized to the host application's clock, it's easy to set up precise rhythmic effects, and feedback can accentuate this.

## damp

Reduces the high frequency content of successive echoes, emulating real spaces: high frequencies are more readily absorbed (by carpets, trees etc.) than low frequencies.

## Tone controls

---

ACE doesn't have a classic EQ, but the pair of tone controls offer enough high and low boost for most purposes. In an attempt to achieve a bigger sound (often to make up for deficiencies in other areas), many digital synthesizers include a kind of "loudness contour". In contrast, ACE's basic sound is principally the same as analogue synthesizers: its filters do not deliver irritating treble or lifeless bass...

### bass

As some analogue filters (notably classic Moog models) are famous for bass sounds, ACE lets you boost sub-bass frequencies by several decibels.

### treble

Modern mixes often demand ultra-crisp highs from synthesizers. Analogue synths don't deliver these frequencies, but VA (virtual analogue) synths, with their purely digital filters, can. The treble control in ACE compensates for any possible losses due to the analogue-modeled oscillators and lowpass filters. ACE can sound as crisp as you like.

## Effects On/Off

---



In the top righthand corner of the effects panel is a button that switches all effects on or off **globally**, so you can temporarily browse through the raw patches without any effects. Just remember to switch it back on afterwards!

# Tweak Page

The **Tweak Page** is where you will find the thoroughly digital **mapping generator** plus anything else that doesn't fit on the main *synth* panel or is of secondary importance...



## Mapping Generator

Mapping generators are alien to analogue synthesizers, and the mapping generator is the only “digital” type module implemented in ACE. Paradoxically, it is great for adding some of the important characteristics of analogue synthesizers – per-note tuning irregularities, non-linear modulation curves etc..

The mapping generator is a list of 128 editable values that can be used for various modulation purposes. For instance you can assign a separate value to every MIDI note (0 to 127) so that each one sounds consistently different, you can emulate a classic *round-robin* architecture or pan stacked voices apart etc..

The mapping generator actually has two outputs: Firstly, the socket at the bottom of the *synth* page labelled **mapper**. Secondly, the LFO2 output when in [tap map](#) mode.

## map modes



*Typical uses for ACE's mapping generator: quasi-random, sequencer, modulation-shaper*

**map smooth** and **map quantized** – both these modes take a selectable source (including wheels and envelopes) to scan through the map. For instance, to transform a simple envelope into a complex one with hills and valleys, or make abrupt timbral changes via velocity etc.. In *map smooth* mode, the values are interpolated for softer transitions. In *map quantize* mode the values are not interpolated, so this is usually the better choice for e.g. sequencer-type effects or sharp transitions.

Note: A **mapping source** is only used in the *map smooth* and *map quantize* modes. It is ignored in *increment* and *key* modes...

**increment** – successive notes step through the map (play a few keys and watch the highlighted bar move from left to right). The default map is a list of 128 quasi-random values, but even a two-value map can be useful.

Example: To pan stacked voices apart, connect the mapping generator to VCA pan modulation, set *stack* to 2 and the number of mapping generator steps to 2, set the map values to maximum and minimum and the mode to *increment*.

**key** – selects a position within the map according to which notes are being played. If the map contains 128 values, these correspond directly to MIDI notes 0 to 127. If the numbers of steps is less than 128, the list is repeated. For instance, setting 12 steps will let you tune each note (C, C#...) in all octaves at the same time.

## Drawing and Selection

To edit the map, simply draw in the window. For straight lines, hold down ctrl (Windows) or option/alt (Mac) while drawing. To make a selection, hold SHIFT: the functions (see the next page) will be restricted to the current selection.

To deselect, either click in the background (anywhere away from the current selection), or choose *Deselect* from the *Selection* sub-menu...

## Context menu

Right-click on the Mapping Generator's window reveals the map editing tools. Hold SHIFT and draw horizontally to restrict the scope of the functions. Hold alt (Windows) or cmd (Mac) then draw to apply the drawing functions.

**Copy / Paste** copies the current map to the clipboard, or replaces the current map with a previously copied one.

**Shapes** contains ready-made *Ramp*, *Triangle*, *Sine*, *Cosine*, *Root* and *Quadric* curves. The final function, *Spectralize*, is especially useful for LFO2 *tap map* mode: It interprets the map data as the levels of partials in the harmonic series. With each partial getting a random phase, these are transformed into the corresponding waveform. The number of values is then automatically reset to maximum (128). Additive synthesis!

**Alt-Draw** (Win) or **Cmd-Draw** (Mac) sets the drawing mode to *Erase*, *Scale* (multiply), *Shift* (2D move) or *Warp* (2D bend).

**Selection** – *Deselect*, *Invert*, *Shift Left*, *Shift Right*, *Select every 2nd*, *Select every 3rd*, or *Select every 4th*. If nothing is currently selected, the first 4 options will not appear in the submenu.

**Reverse** flips the window or selection horizontally

**Invert** flips the window or selection vertically

**Randomize** – random offsets applied to the existing values

**Soften** removes abrupt transitions

**Normalize** scales all values in the window or selection so that the lowest and highest are at the bottom and top.

**Make Unipolar** shifts all values into the positive

**Straighten** draws a straight line between the first and last values in the window or selection.

**Reset** sets all values in the window or selection to zero.

**Quantize 4, 6, 8, 12, 16, 24** quantizes all values to the specified number of levels. Tip: the 12 and 24 settings are especially useful for setting up little sequences: connect the map output to a pitch input, set the amount to 12 or 24 semitones, then use the *ramp generator* with *rest* set to minimum as the mapping source. Simpler still: use LFO2 with the *tap map* waveform!

**2 to 12, 16, 24, 32, 48, 64, 96 or 128** set the number of used i.e. visible steps in the mapping generator. Note that the original data is retained when the number of steps is reduced.

Copy
Shapes >
Cmd-Draw >
Selection >
Reverse
Invert
Randomize
Soften
Normalize
Make Unipolar
Straighten
Reset
Quantize 4
Quantize 6
Quantize 8
Quantize 12
Quantize 16
Quantize 24
2
3
4
5
6
7
8
9
10
11
12
16
24
32
48
64
96
128
Lock

## Stacked Voice Tuning

---



### voice 1... voice 8

This block of 8 knobs tunes the individual voices within a [stack](#). The total range for each voice is +/- 24 semitones, so as well as setting up mild detuning you can even create massive one-finger chords. For fine tuning, hold down the SHIFT key on your computer keyboard. Remember: Stacking voices will significantly increase the CPU-hit per played note!

## Circuit Bending

---



### slop

Attributed to Dave Smith of *Sequential Circuits* and *DSI*, this has recently become the term of choice for tuning instabilities. The Slop parameter in ACE adds subtle and slow random detuning.

### crosstalk

Once considered a less desirable feature of analogue synths than unstable tuning, even crosstalk has its own special charm in this digital age. Quoting Wikipedia:

*Crosstalk is any phenomenon by which a signal transmitted on one circuit or channel of a transmission system creates an undesired effect in another circuit or channel.*

## osc cap failure

Finally, let's make sure the capacitors in your emulated analogue synth sound like they will need replacing very soon. No joke, that's what this parameter emulates... try it!

## filter reset

**none** .....quasi 'free-running', transients may have a little analogue randomness

**full** .....reduces randomness by flushing the filter at the beginning of each note: presets with self-oscillating filters will fade in more slowly

**full+click** .....the same as full but with an extra strong transient at the start of each note: use this mode for filter 'self-oscillation'

## Envelope Tweaks

---

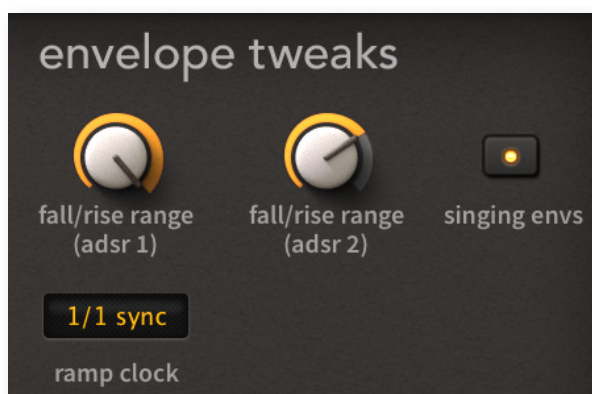

### fall / rise ranges

These two knobs affect the level after [fall/rise](#) for each of the ADSRs. Normally this would be either maximum (positive fall/rise) or zero (negative fall/rise). The range knob sets a percentage of the difference (from the sustain level) instead of always 100%.

### singing envs

Switching **singing envs** on causes the envelope of a new voice to start at the current level of the stolen voice's envelope instead of at zero, more closely emulating a typical behaviour of classic analogue hardware envelopes.

### ramp clock

This switch sets the maximum of the ramp generator stages to either absolute time or host-synchronized values: **0-20 sec** is absolute time with maximum 20 seconds per stage, while **1/1** and **4/4** are synchronized to song tempo. Note: The ramp generator scaling is absolutely linear, so setting e.g. an attack time of 25 will divide the maximum by four (i.e. it will be 5 seconds, 1/16 or 1/4 long)

## Microtuning

---

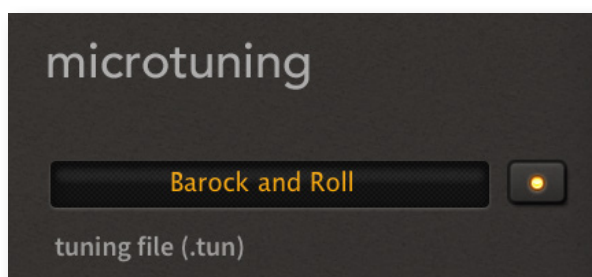

ACE supports standard .TUN microtuning tables. ACE already includes a few tables, but hundreds or even thousands of free tuning tables are available online. Put any .tun files into the following folder (this location will differ if you selected non-standard paths during installation):

**Win** *C:\Users\\*YOU\*\Documents\u-he\ACE.data\Tunefiles\*

**Mac** *Macintosh HD/Library/Application Support/u-he/Tunefiles/*

To activate microtuning, click on the button to the right of the selector.

### MTS-ESP

ACE supports [Oddsound](#) MTS-ESP, a system for microtuning multiple plug-ins within a DAW environment. The freeware 'Mini' version is all you need to get started.

Note that MTS-ESP can be overridden by activating ACE's own microtuning, for instance with the .tun file *Default Scale*.

# Configuration

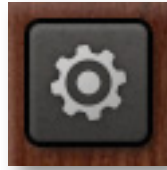

Click on the cogwheel icon at the top right to open the global configuration pages where you can connect ACE parameters to MIDI continuous controllers as well as specify several global preferences. A vertical row of buttons appears instead of the cogwheel: Close [X], MIDI Learn [L], MIDI Table [≡] or Preferences [tools].

Tip: Right-click within the row of buttons to set the current page as default.

## MIDI Control

---

### About MIDI CC

Before connecting knobs and sliders on your master keyboard to ACE parameters (see the next page), it's best to know what a MIDI CC is...

CC, which officially stands for Control Change now (it used to be "Continuous Controller"), is a multi-purpose message format for performing as well as editing presets. Note that CC isn't the only kind of MIDI performance data available; there are also messages for note on/off (including velocity), pitch bend and two kinds of aftertouch.

Later revisions to the MIDI spec even included a bunch of overly specialized CC definitions such as Celeste Detune Depth – presumably at the bidding of a home organ manufacturer or two. We can safely ignore all those names...

Thankfully, the MIDI Manufacturers Association (MMA, a.k.a. MIDI Association) left most of the CC numbers undefined, but two of them have specific meanings which are also recognized by ACE:

CC#01 = modulation wheel

CC#64 = sustain pedal

Earlier versions of ACE also offered the modulation sources Breath (CC#02) and Expression (CC#11). These have been replaced by the user-definable **Control A** and **Control B**. See the [Preferences](#).

You don't need a hardware breath controller or expression pedal to make use of CC messages! Most of the MMA-specified names are little more than convention: You can use anything that can send CC messages, for instance a knob or slider on your MIDI keyboard, or a controller lane in your MIDI sequencer.

## MIDI Learn

ACE can be remote-controlled / automated via MIDI messages from a hardware controller unit or from your host sequencer. Click on the configuration button and select the 'L' icon...



The MIDI Learn window is an overlay with all MIDI-learnable elements appearing as selectable outlines. Controls that are already assigned appear filled (like a few of the controls in this image), and the currently active control is highlighted. Try it: Click on the Filter 1 cutoff knob and send ACE some MIDI CC data i.e. move a knob or slider on your MIDI controller. The connection is made instantly, and applies to all instances of ACE.

Note that the SYNTH and TWEAKS buttons remain active while the MIDI Learn page is open, so you don't have to exit the configuration pages to access all parameters.



## MIDI Table

Click on the configuration button and select the triple bar MIDI icon button to open an editable list of all current **MIDI CC** assignments:

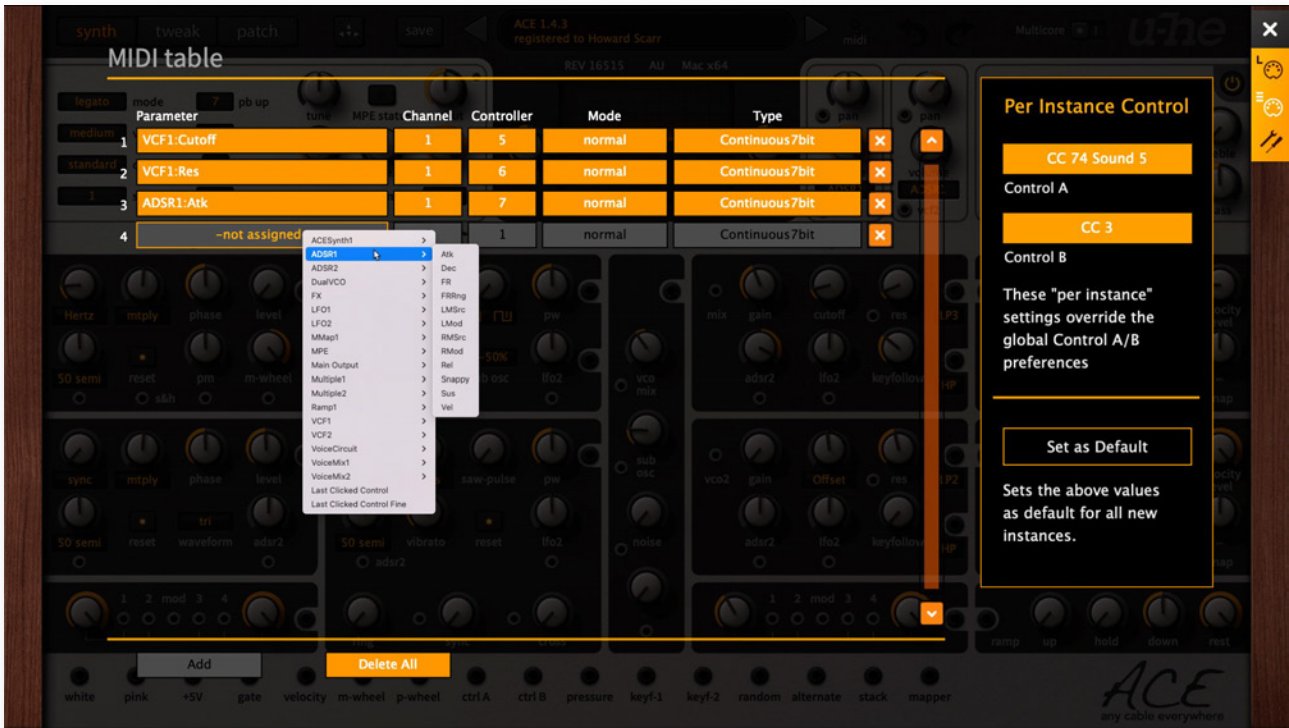

## Parameter

The first field displays/selects one of ACE’s many parameters, sorted into sub-menus. Click on the ‘Add’ button at the bottom and experiment with this option. Delete any unwanted assignments by clicking on the small [x] to the right of each line.

Here’s an experimental feature... At the very bottom of the Parameter menu are two extra options. Select *Last Clicked Control*, enter a Controller number and exit the configuration pages. The most recently clicked knob or switch will now respond to that CC! The *Last Clicked Control Fine* option is similar, but with a significantly reduced range.

## Channel / Controller

The next two fields are for MIDI channel and CC number. ACE is channel-sensitive, so you can map up to 16 channels for... let’s say “lots” of control assignments.

## Mode

Specifies the range and/or resolution of values.

**normal**.....full range, continuous

**integer**.....full range, whole numbers only

**fine**.....0.01 steps between the two integers closest to the current value

## Type

The kind of hardware controls. The most common type by far is **Continuous7-bit**.

**Encoder127**.....'relative mode' endless rotary controls that repeatedly send the CC value 1 when turned in the positive direction, or 127 (interpreted as -1) when turned in the negative direction

**Encoder64**.....'relative mode' endless rotary controls that repeatedly send the CC value 65 when turned in the positive direction, or 63 when turned in the negative direction

**Continuous7-bit**.....'absolute mode' rotary controls or sliders that send 7-bit CC i.e. normal resolution (very common)

**Continuous14-bit**.....'absolute mode' rotary controls or sliders that send 14-bit CC i.e. high resolution (quite rare)

If in doubt, please refer to the documentation about your hardware controller.

## Delete

To remove individual assignments, click on the [x] to the right of each line. To remove all assignments, click on the [Delete All] button at the bottom of the window.

## Per Instance Control

Local versions of the [Control A](#) and Control B Default settings in the Preferences:

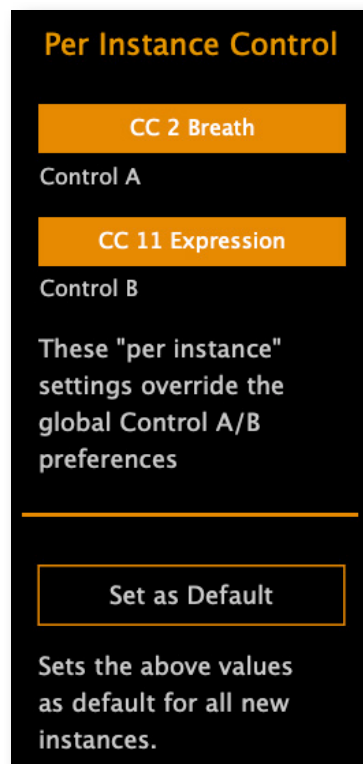

To set a different CC either click and select an entry from the (rather long) menu, or hover over the field and roll your mouse wheel. [Set as Default] copies these settings to the global Preferences...

## Preferences



Click on the 'tools' icon to open the global **preferences** window:

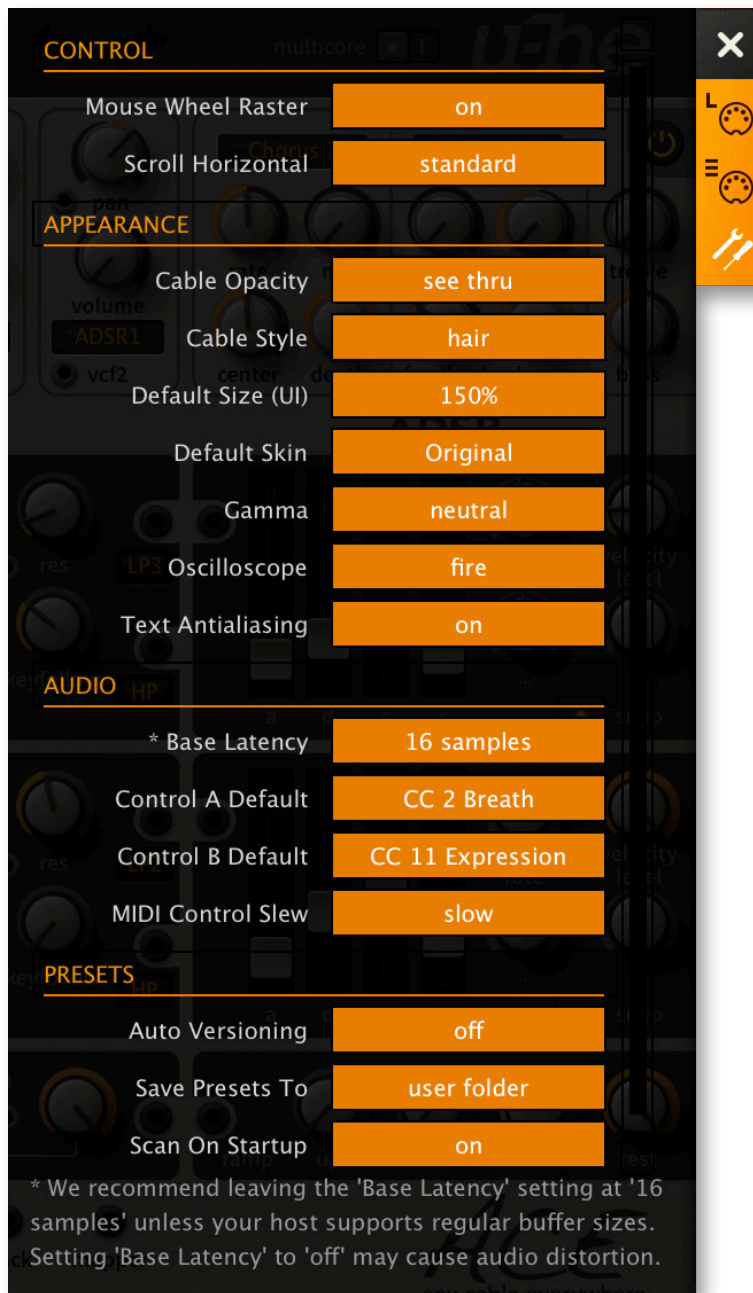

## CONTROL

### Mouse Wheel Raster

If your mouse wheel is rastered (you feel it clicking slightly as you roll the wheel), set this to 'on'. Each click should now increment / decrement by a sensible step.

### Scroll Horizontal

Folders that contain more files than can be displayed in the window (e.g. '02 Leaders') can be scrolled pagewise via mousewheel etc.. Opinions differ about which direction the wheel should be moved, so we made this optional.

## APPEARANCE

### Cable Opacity

4 options (*solid* to *ghosted*). Note that you can change the cable opacity per instance without entering the *Preferences* page – right-click on any used input.

### Cable Style

5 options (*thick* to *natural*). Note that you can change the style per instance without entering the *Preferences* page – right-click on any used input.

### Default Size (UI)

The window size for new instances of ACE. Note that you can temporarily change the size without entering the *Preferences* page – right-click anywhere in the background.

### Default Skin

This option will only appear if ACE finds at least one alternative skin when it loads. Change this to set the global default. Note that you can temporarily change the skin without entering the *Preferences* page – right-click anywhere in the background.

### Gamma

Brightness control.

### Oscilloscope

How the oscilloscope wave is drawn, 5 options (*eco* uses the least CPU).

### Text Antialiasing

Smoothing of all text elements. In rare cases, switching this off improves readability.

## AUDIO

### Base Latency

If you are sure that your audio system – hardware and software – uses buffers that are a multiple of 16 samples in size (please refer to the respective documentation), you can disable ACE's base latency. Otherwise leave it set to the default '16 samples' to prevent crackles. Note that a new Base Latency setting will only take effect when the host allows e.g. on playback or after switching sample rate. Reloading ACE will always work.

#### ABOUT THOSE BUFFERS

Internally, ACE processes audio in chunks of  $n \times 16$  samples. This 'block processing' method significantly reduces the CPU load and memory usage of all our plug-ins.

If the number of samples to be processed is say 41, ACE processes the first 32 and keeps the remaining 9 in a small buffer (16 samples is enough). Those 9 samples are then processed at the start of the next call... and so on.

The extra buffer is only necessary if the host or audio driver processes 'unusual' buffer sizes. In the many host applications that process buffers of e.g. 64, 128, 256 or 512 samples (all multiples of 16), try switching it off so that ACE can process latency-free.

### Control A Default, Control B Default

Apart from the modulation wheel, the list of performance modulation sources in previous ACE versions included the fixed MIDI continuous controls 'Breath' (CC#02) and 'Xpress' (CC#11). We replaced these with the user-definable **Control A** and **Control B** sources, while retaining backwards compatibility.

Note that these can both be overridden by '[Per Instance Control](#)' in the MIDI Table view.

### MIDI Control Slew

This option lets you change performance control smoothing (pitch bend, modulation wheel, breath, expression and aftertouch). The default setting is 'fast'.

## PRESETS

### Auto Versioning

If switched on, an index is appended to the preset name and automatically incremented each time you save it. For instance, saving 'Space' three times in a row would give you three files: 'Space', 'Space 2' and 'Space 3'

### Save Presets To

The default *user folder* option causes all saved presets to land in the User folder (or a selected subdirectory). If you prefer to have complete control, change this to *selected folder* – but always remember to select a folder before saving your patch.

### Scan On Startup

Whether the preset library should be scanned and the database recreated when the first instance of ACE is started, e.g. when you reopen a project.

# MIDI Specialities

## MIDI Programs

---

Presets in this folder are loaded into memory when the first instance of ACE starts, after which they can be switched via 'Program Change' messages. As they are accessed in alphabetical order it is best to prefix names with an index '000' to '127'.

The MIDI Programs folder can contain up to 127 sub-folders of 128 presets, switched via MIDI 'Bank Select' messages (CC#0) preceding the Program Change message. The MIDI Programs folder itself is bank 0, sub-folders are addressed in alphabetical order starting with bank 1.

When ACE receives a program change, it will display the bank and program numbers to the left of the preset name e.g. "0:0" for the first preset in the first bank. In certain hosts, however, the first bank / preset is designated "1" instead of the correct "0".

IMPORTANT: Unlike regular presets, MIDI Programs cannot be added, removed or renamed on the fly. Changes will only take effect after the host software is restarted!

To avoid another possible source of confusion: Please check that there are no junked presets in the MIDI Programs folder, as all files are addressed – even if hidden!

## CLAP

---

If you are running ACE in a CLAP-capable host we recommend using that format in preference to VST or AU. CLAP includes several advanced features which are not available in the older formats, including time stamped parameter changes, Note Expressions, and Parameter Modulation. Note: CLAP's Brightness expression is permanently mapped to Control A in ACE. More information at <https://cleveraudio.org>

## Polyphonic Aftertouch

---

As well as normal aftertouch, ACE recognises polyphonic aftertouch, which affects individual notes rather than all notes at once. Both types are combined in the *Pressure* modulation source.

## Multichannel MIDI

---

Similar to MPE (see the next page) but simpler, Multichannel MIDI allows notes to be distributed between the 16 MIDI channels so that they can have different *expression*: Each channel will respond individually to *Pitch bend*, *Pressure* (aftertouch), *Modulation* (MIDI CC #01), *Control A* and *B* (user-definable MIDI CC).

Multichannel MIDI does not require activation. However, your host app must allow multiple MIDI channels to be routed to a single instance of Hive. Multichannel MIDI is automatically disabled whenever MPE is active.

## MPE

---

Multidimensional Polyphonic Expression: ACE supports a growing class of instruments capable of sending notes on separate MIDI channels so that they can be articulated individually. Note: For ACE to respond correctly, the host application must allow multiple MIDI channels to be routed to a single instance of a plug-in.

### From MIDI to MPE

Most MIDI keyboards have a pair of left-hand performance controls which affect all notes played to the same degree: pushing the modulation wheel / joystick causes all notes to respond in parallel according to whatever has been programmed in the current preset. The same is normally true for pitch bend and channel aftertouch (aka pressure), but not when MPE comes into play: The MPE protocol allows voices to be articulated independently...

MPE defaults to an extended version of MIDI Mode 3 (aka Poly Mode), with MIDI channel 1 acting as *Manager Channel* for up to 15 *Member Channels*. MPE assigns each note a new MIDI channel with its own performance data. For example, individual notes within a chord can be bent like on a pedal steel guitar, or notes can be otherwise articulated individually like a vocal quartet. It is up to the receiving device (e.g. ACE) to interpret the MPE data appropriately, and it's up to the sound designer to use these data in a musically meaningful way.

Note: MPE was designed to work with either a single polyphonic synthesizer or a number of monophonic synths in parallel. At the time of writing, most controllers and DAWs only implement the single polysynth option, which is catered for in ACE by setting the Voice Mode to *poly*. If you are the lucky owner of a host that also implements the multiple mono synths option you can set ACE's voice mode to *mono* or *legato* so that e.g. trills and legato glide become available for each channel. ACE's duo mode is not recommended while MPE is active, as there is no suitable specification for it.

MPE controllers are responsible for ensuring that all controllers have sensible values before each Note On is sent. If you experience glitches here, please check whether your MPE controller is sending suitable pitch bend, pressure and CC#74 (see below) values, then contact the manufacturer if necessary.

### Member channels

To keep the MIDI stream manageable, MPE only sends notes, pitch bend, channel pressure and CC#74 (see below) on member channels: All other CC data including mod wheel (CC#01) and hold pedal (CC#64) are sent on channel 1 and therefore remain global i.e. they apply to all voices. Some MPE instruments include a traditional pitch bender for all voices, while lateral motion of the keys (or pads) bend individual notes.

MPE polyphony is not restricted to 15, the number of member channels. The trick is to freeze the performance data of notes upon release (i.e. MIDI Note Off): New notes can reuse MIDI channels without the new performance data affecting released notes that are still audible.

Please remember that the idea behind MPE was to capture expressive performances, not to micromanage note data on your computer. Editing MPE in existing DAWs is not recommended for the faint-hearted.

## About CC#74 (Timbre)

Alongside pitch bend and aftertouch, MPE specifies a third dimension of per-note control called **Timbre**, which uses CC#74. For full MPE compatibility, Control A **must** be set to MIDI CC#74...

## MPE Settings

If you own an MPE-capable instrument you can activate MPE and adjust a few settings in ACE to make the most of the MPE performance features.

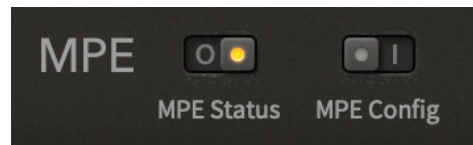

MPE status can be switched on/off from the [General Settings](#) panel, from the bottom right of the **Tweaks** window (shown here), or from within the **MPE config** window itself. Clicking on [MPE Config] opens this dialogue box:

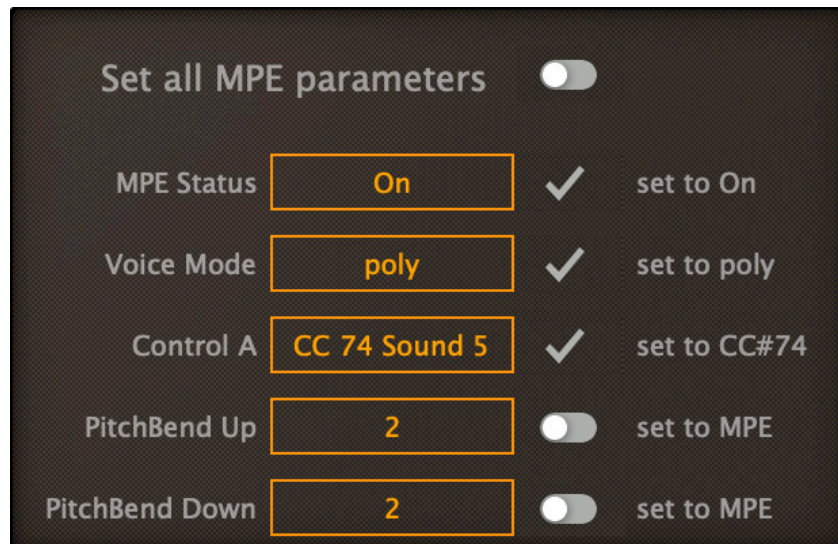

### Set all MPE parameters

The button at the top switches all five MPE-relevant parameters to their MPE default values. Values that differ from the MPE defaults appear as horizontal switches. Those set to default MPE values are replaced with ticks.

Click on the central fields to open their menus, or hover and roll your mouse wheel.

### MPE Status

Activates / deactivates MPE mode, mirroring [MPE Status] in the [general settings](#) panel.

### Voice Mode

Mirrors the *mode* parameter in the [general setting](#) panel. Set *poly* for standard MPE.

## Control A

Control A **must** be set to MIDI CC#74. Adopted as [Per Instance Control](#) in the MIDI Table (which overrides the global preference [Control A Default](#)). Note that this setting does not automatically revert to its previous state when you switch MPE off.

## PitchBend Up / Down

These two values mirror the 'pb' settings in the [general setting](#) panel. Setting MPE here means a pitch bend range of +/- 48 semitones! Depending on your specific MPE controller, consider using e.g. +/-2 instead.

MPE exposes the pitch bend range for each voice to the host via special RPN messages (these "registered parameter numbers" are used to extend MIDI beyond the 128 controller limit). If you set appropriate ranges for the specific patch instead, they will be interpreted correctly.

For MIDI experts: Pitch bend ranges on the manager channel are +/-2 by default, but can be overridden via RPN messages from the MPE source.

If you have any trouble playing ACE in MPE mode, please study the documentation of your MPE instrument and the host application carefully before reporting a bug to u-he. MPE is complicated!

Depending on how popular they become, the [FAQ page](#) at u-he might include a few tips for the more common MPE instruments.