

REPRO-1 USER GUIDE

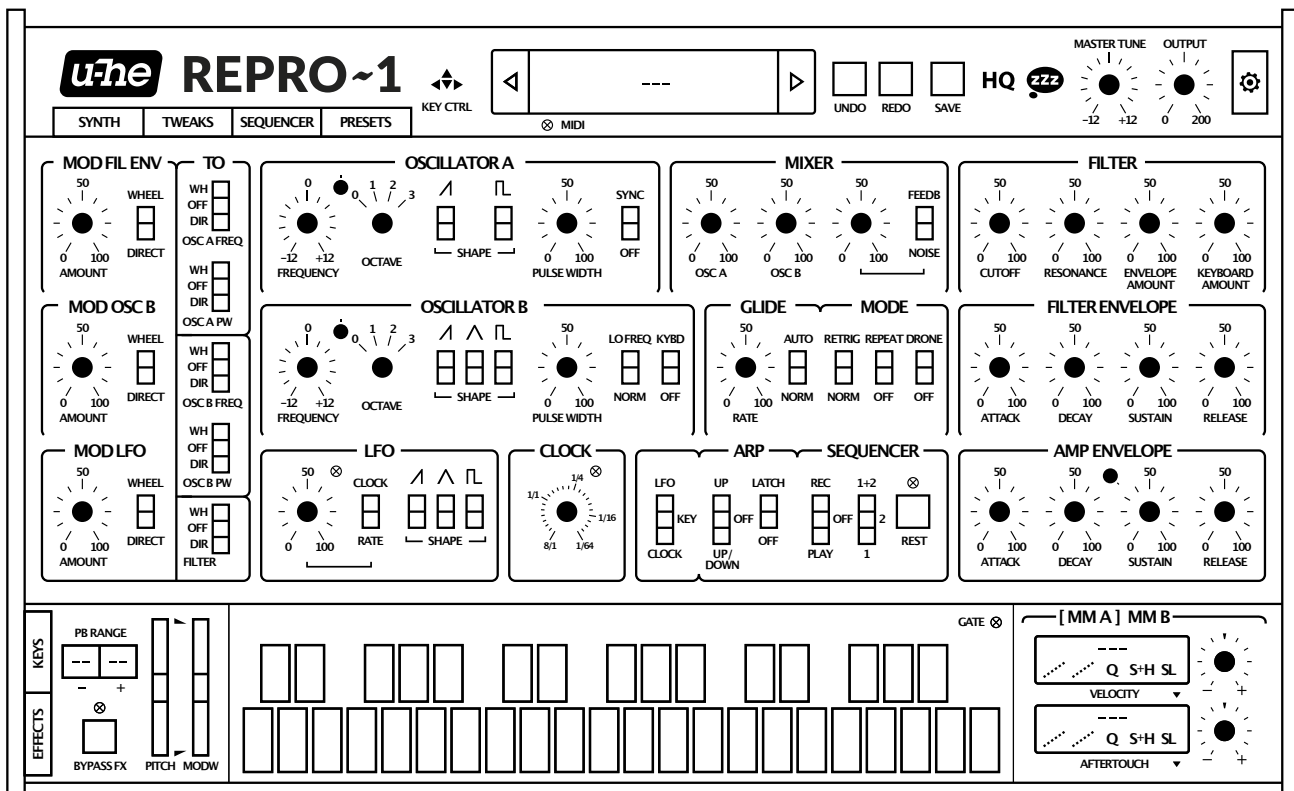

**HECKMANN
AUDIO**

Repro-1 SYNTHESIZER
OPERATION MANUAL
 by Heckmann Audio



1	INTRODUCTION	4
	1-1 INSTALLATION	4
	1-2 RESOURCES	5
	1-3 KNOBS AND SWITCHES.....	5
	1-4 CONTROL BAR.....	6
2	PRESET BROWSER	7
	2-1 DIRECTORY PANEL	8
	2-2 PRESETS PANEL	10
	2-3 DRAG & DROP.....	11
	2-4 INSTALLING SOUNDSETS	12
	2-5 TAGGING	13
	2-6 SEARCH BY TAGS	14
	2-7 SEARCH BY TEXT	16
	2-8 SMART FOLDERS	18
3	SYNTH	19
	3-1 VOICE SIGNAL FLOW.....	19
	3-2 OSCILLATOR A	21
	3-3 OSCILLATOR B	22
	3-4 GLIDE & MODE	22
	3-5 MIXER	23
	3-6 FILTER.....	23
	3-7 FILTER ENVELOPE	24
	3-8 AMP ENVELOPE	25
	3-9 LFO.....	26
	3-10 MODULATION SECTION	26
	3-11 CLOCK.....	29
	3-12 ARP / SEQUENCER (basic access).....	29
4	SEQUENCER	31
	4-1 PATTERN data	31
	4-2 SEQUENCER control.....	32
	4-3 EDIT	33
5	KEYS / MOD MATRIX	34
6	EFFECTS	38
	6-1 JAWS wavefolder.....	38
	6-2 LYREBIRD delay.....	40
	6-3 RESQ resonator / equalizer	41
	6-4 DRENCH reverb.....	42
	6-5 SONIC CONDITIONER.....	43
7	TWEAKS	44
	7-1 JUMPERS.....	44
	7-2 SELECTORS.....	45
8	CONFIGURATION	47
	8-1 ABOUT MIDI CC.....	47
	8-2 MIDI LEARN	47
	8-3 MIDI TABLE	48
	8-4 PREFERENCES	49
9	NKS	52
10	Troubleshooting	53

1 INTRODUCTION

1-0 HISTORY

Repro-1 is a component-level model of perhaps the most powerful-sounding monophonic keyboard ever built. When its 4-year production run started in the early 1980s, polyphonic synthesizers were almost within reach of the average musician. To be commercially viable, any new *monophonic* instrument had to be cheap but very capable. Fat drones, cutting leads, funky basses, quirky sci-fi sound effects – this synthesizer delivered on all counts.

The circuit design made good use of standard Curtis chips (3340 oscillator, 3320 filter and 3310 envelope) and the little onboard sequencer was more than just a welcome extra. Despite its molded plastic panel and the limitations of monophony, it sold surprisingly well and is generally recognized as an iconic piece of synthesizer history. Soaring prices guaranteed.

So here's our plug-in version, **Repro-1**: All the lovable quirks of this classic synth, but with a much more capable sequencer, lots of presets, effects and under-the-hood tweaks. Enjoy!

- Urs and the team

1-1 INSTALLATION

The following procedure installs both Repro-1 and Repro-5 on your hard disk

Go to the [Repro](#) web page, download the latest installer for your system (Mac/Win). Unzip the compressed file, open the *Repro-1* folder and start the installer application. The only demo restriction is a mild crackling at irregular intervals after about two minutes of use. The demo is otherwise fully functional. Those crackles disappear after you have purchased a license and entered the serial number. For more information, please refer to the *ReadMe* file included with the installer. By default, Repro-1 uses the following directories:

Windows

Presets (Local)	C:\Users*YOU*\Documents\u-he\Repro-1.data\Presets\Repro-1\
Presets (User)	C:\Users*YOU*\Documents\u-he\Repro-1.data\UserPresets\Repro-1\
Preferences	C:\Users*YOU*\Documents\u-he\Repro-1.data\Support\ (*.txt files)
Alternative skins	C:\Users*YOU*\Documents\u-he\Repro-1.data\Support\Themes\

Paths containing non-standard characters are not supported. If a previous installation into e.g. the *VstPlugins* folder didn't cause any file permissions problems, you can safely reinstall there.

macOS

Presets (Local)	MacHD/Library/Audio/Presets/u-he/Repro-1/
Presets (User)	MacHD/Users/*YOU*/Library/Audio/Presets/u-he/Repro-1/
Preferences	MacHD/Users/*YOU*/Library/AppSupport/u-he/com.u-he.Repro-1... (*.*)
Alternative skins	MacHD/Library/AppSupport/u-he/Themes/
Other resources	MacHD/Library/AppSupport/u-he/Repro-1/

To uninstall Repro, delete the plugin files and the above folders.

Important: Realtime malware scanners (e.g. Windows Defender) allowed to scan u-he plugin resources will slow down the browser considerably, depending on the number of presets. Please add the Repro-1.data folder to the scanner's exceptions list (you can rest assured that we haven't put any executable files in there). Mac owners using a malware scanner should add the above */u-he/* resource directories to the exceptions list.

1-2 RESOURCES

u-he online

For downloads, news and support, go to the [u-he website](#)

For heated debates about u-he products, go to the [u-he forum](#)

For friendship and informal news updates, go to our [facebook page](#)

For u-he presets (paid or free), go to u-he preset library [PatchLib](#)

For video tutorials and more, go to our [youtube channel](#)

For personal pics and a few videos, go to our [instagram page](#)

For audio demos of soundsets, go to our [soundcloud](#)

u-he team 2025 (Q4)

Urs Heckmann (concepts, code); Jayney Klimek (accounting, procurement); Howard Scarr (sound design, user guides, grump); Sebastian Greger (UI design, 3D graphics); Jan Storm (framework, hardware code); Oddvar Manlig (business development); Viktor Weimer (customer support, sound design); Thomas Binek (QA, betas, customer support); Henna Gramentz (accounting, customer support); Frank Hoffmann (framework, browser); Alf Klimek (studio, voiceovers); Sebastian Hübner (media creation); David Schornsheim (framework, CLAP); Kay Knofe (hardware development); Tim Fröhlich (more code); Sadjad Siddiq (DSP); Petros Karagkounidis (web development); Simon Schrape (web development), Max Steimel (DSP); Henry Lau (accounting, customer support); Mine Hahn (DSP), Vadim Zavalishin (filter design, DSP).

1-3 KNOBS AND SWITCHES

The knobs respond to vertical click & drag and to mouse wheel movement (no clicks required). You can **fine tune** most parameters, most often with a resolution of 0.01, by holding down SHIFT before clicking on the knob. How switches react depends on a global preference called *Switch Behaviour* – see the [Configuration](#) chapter.

The name and value of the control currently being edited appears in the **data display**, which you will find in the middle of the control bar (see below).

Parameter Locking: To prevent a value from changing when you switch presets, use the *Lock* function – right-click on any control and select the last entry in the menu. Don't forget to unlock afterwards, otherwise presets will sound “wrong”.

Entering values: The value of the most recently used control can be set by entering numbers on your computer keyboard. Switches take integer indices e.g. you can set *Clock* to 1/16 by entering '19'. Please note that hosts respond differently to keyboard strokes while a plug-in has the focus – you might have to set an option to allow this feature. If in doubt, please refer to the documentation of your host app.

1-4 CONTROL BAR



u-he Badge: Clicking on **u-he** opens a popup menu containing links to this user guide, to our homepage, to our support forum, and to various social networks.

SYNTH, TWEAKS, SEQUENCER, PRESETS: These buttons switch between Repro-1's four basic views. To ensure that each new instance will open in the current view, right-click anywhere within the row of buttons and select *set current as default*.

KEY CONTROL: Experimental feature, work in progress! For various reasons we recommend using a numeric keypad a.k.a. numpad.

Activate, then either click on any knob or navigate using your cursor keys. Type a numerical value and confirm via Return or Enter. For negative values, type minus (-) before confirming.

Backspace recalls the default value. Increment / decrement integers via (+) and (-) on the numpad. Hold shift for fine control, or option (Mac) / ctrl (Win) key for steps of 10. System copy/paste and undo/redo shortcuts should work as expected. Video and discussion: <https://www.kvraudio.com/forum/viewtopic.php?t=611856>.

MIDI activity: An indicator which flashes whenever MIDI data is being received.

Data Display: Normally shows the name of the preset. Clicking on the triangles steps through presets, clicking in the middle of the display lets you select a preset from the current folder or load an *init* preset. While editing, the parameter name and value will appear in the display.

UNDO / REDO buttons: To the right of the data display is a pair of buttons you can use to fix any 'mistakes'. You can even undo a change of preset.

SAVE button: Stores the preset into either the currently selected folder or the 'User' folder, depending on the *Save Presets To* preference (see [chapter 8](#)). Right-clicking on [SAVE] opens a menu with a choice of file formats. The recommended *h2p* option is our cross-platform format (editable text), while *h2p extended* includes extra readable info. The *native* option is the standard format of your system (.fxp for VST and AAX, .aupreset for Audio Units). An *nksf* option also appears in the VST version – see [chapter 9](#).

Note: The following switches are global per instance i.e. they are not saved with each preset: HQ, zZz, BYPASS FX, arpeggio LATCH, sequencer ON KEY | ALWAYS.

HQ button: Global *High Quality*. Should only be necessary for extreme FM sounds.

zZz button ('Sleepy'): Reduces the CPU consumption when Repro-1 isn't playing any notes.

MASTER TUNE: Tunes the preset within a range of +/- 12 semitones. For fine tuning, hold down a SHIFT key on your computer keyboard while adjusting.

OUTPUT: Final volume control, after the amplifier and all effects. Normally set to 12 o'clock.

Configuration button (cogwheel): Access to MIDI options and global prefs. See [chapter 8](#).

2 PRESET BROWSER

In the control bar, click on the PRESETS tab. You should see something like this:

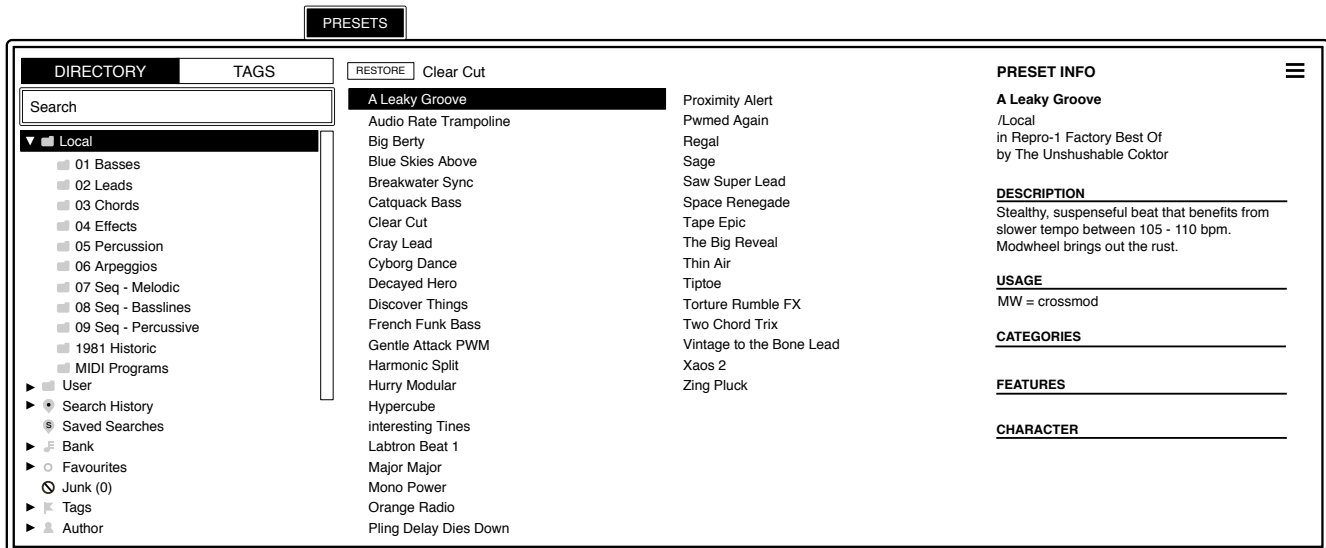

Folders appear on the left (drag the scrollbar to see more), presets appear in the centre and information about the currently active preset appears on the right. If you can't see any presets at all, click on *Local* then on *01 Basses* (for instance). If you don't see a PRESET INFO panel, click on the [≡] button in the top right corner and activate *Show Preset Info*.

Note: The Local root directory contains a representative selection of presets.

To load a preset, click on its name. Immediately after selecting a preset you can step through all the others using your computer's cursor keys.

Default, initialize

Whenever Repro-1 is started it checks whether the 'Local' root contains a preset called *default*. If this file exists, it is loaded instead of the demo sound.

If you want Repro-5 to start with a simple template instead of the default preset, right-click on the data display and select *init* (initialize). Check that the 'Local' root directory is currently open then [SAVE] your preset under the name *default*.

Note that *default* will not appear in the browser. If a fresh instance of Repro-1 is not loading your new *default*, it probably landed in 'User' instead, in which case you should change the *Save Presets To* setting (in Configuration/Preferences) and repeat the above.

More Sounds

Soundsets we sell online are in the *.uhe-soundset* format (see [2-5 INSTALLING SOUNDSETS](#)). Many 3rd party sounds, commercial as well as free, are also available via [Patchlib](#).

2-1 DIRECTORY PANEL

If you don't see this panel in Repro-1's PRESETS browser, click on DIRECTORY.

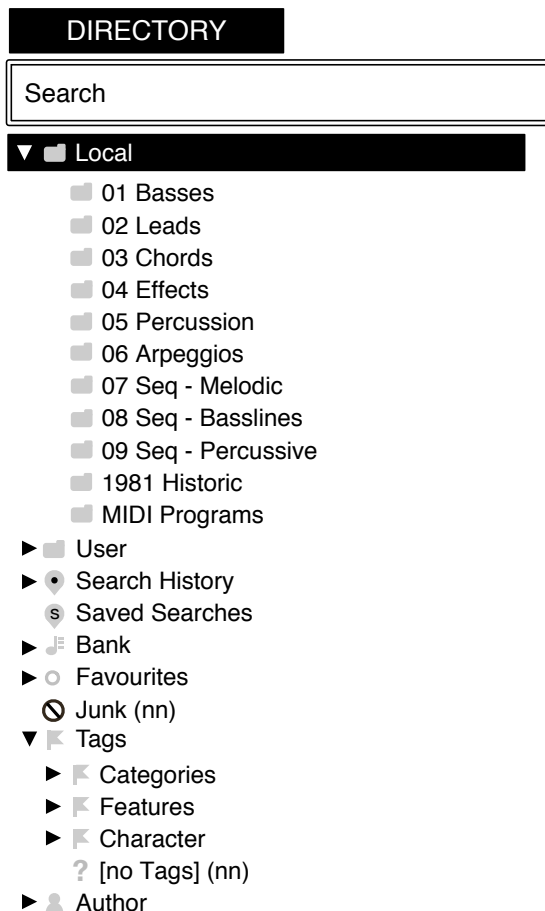

The 'Local' folder

Repro-1's factory presets are sorted into folders **01** to **09**. We recommend that you do not add or remove any presets there, but save all your creations into 'User' (see below).

Named after the year Repro-1's hardware ancestor first appeared, the **1981 Historic** folder contains 20 presets meticulously copied from patch sheets in the original printed manual.

'Local' also contains a special folder called '**MIDI Programs**', which is normally empty. When the first instance of Repro-1 starts, up to 128 presets from that folder are loaded into memory so they can be selected via *MIDI Program Change* message. It is a good idea to call those presets e.g. '000 rest-of-name' to '127 rest-of-name', as they are accessed in alphabetical order.

But that's not all: the 'MIDI Programs' folder can contain up to 127 sub-folders, switched via *MIDI Bank Select* messages (CC#0). Send *Bank Select* first, then *Program Change*. 'MIDI Programs' is bank 0, sub-folders are addressed in alphabetical order starting with bank 1.

When Repro-1 receives a program change, it will display the bank and program numbers to the left of the preset name e.g. "0:0" for the first preset in the first bank. In certain hosts e.g. Ableton Live, however, the first bank / preset is designated "1" instead of the correct "0".

To avoid another possible source of confusion, make sure that there are no junked presets in the MIDI Programs folder. All files there are indexed, whether they are visible or not.

IMPORTANT: ‘MIDI Programs’ cannot be added, removed or renamed on the fly!
Any changes to that directory will only be updated after the host application is restarted.

The ‘User’ folder

The best address for all your creations! You can either select *User* immediately before saving the preset, or set a global preference which ensures that it will **always** be saved to this folder – see the *Save Presets To preference* in section 8-4.

Tip: It’s worth finding out where the *User* folder resides on your computer, especially if you want to manually install soundsets. Right-click on *User* and select *Open in Finder / Explorer*.

Search History, Saved Searches, Favourites, Junk, Tags

These aren’t regular folders, but *smart folders*. See section 2-9.

Directory context menu

Right-clicking on any folder within *Local* or *User* will open this menu. Note that this menu is dynamic: Some smart folders offer extra options e.g. *Save Search*.

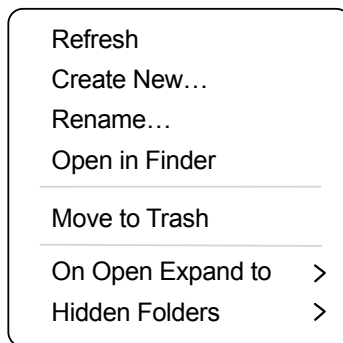

Refresh: Updates the contents of the browser. Required for Windows users.

Create New... Insert an empty subfolder.

Rename... Edit the folder name.

Open in Finder / Explorer: Opens a system window for the clicked folder. If you hold down an option key (Mac) or ctrl key (Windows), the entry will change to *Show in Finder / Explorer* and the folder will be highlighted instead of opened.

Move to Trash / Recycle Bin: Moves the selected folder to the system trash. If you right click on the Junk folder, this entry will be replaced by *Remove All Junk Marks*. If you right click on a Bank folder, it will be replaced by *Remove Presets from Bank* (see SMART FOLDERS).

On Open Expand to: These options determine how deeply the browser will open subdirectories whenever the GUI is opened again or the *refresh* function is called. The first option (*none*) collapses all folders, while the final option (*all levels*) reveals all nested folders.

Hidden Folders: Select the smart folders you don't want to see.

2-2 PRESETS PANEL

The central, unlabelled area of the browser is where you click to load presets...

Presets context menu

Right-click to open a menu containing functions you can apply to individual presets.

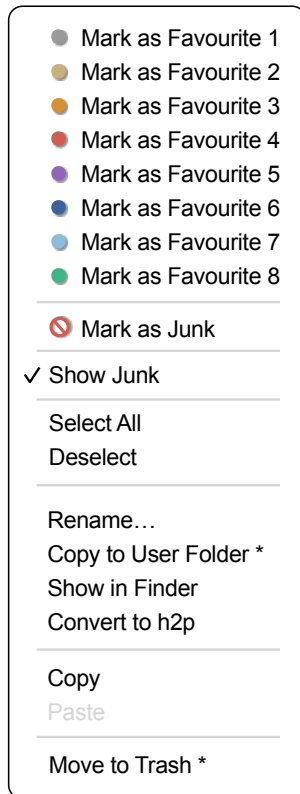

Mark as Favourite: Choose just one of eight differently coloured dots. To remove the dot again, right-click on the preset(s) and select *unmark as favourite*.

Mark as Junk / Show Junk: Instead of deleting unloved presets, mark them as ‘junk’ so that they disappear from the browser. Activate **Show Junk** to display junked files instead, and mark them with a STOP symbol.

Select All, Deselect: See *Multiple Selection* on the next page.

Rename...: You can change preset names with this function. Note that only the most recently selected preset can be renamed i.e. you can’t rename multiple files at once.

Copy to User Folder / Duplicate: This entry depends on the status of Save Presets To as well as on the location of the source preset(s) – whether they are in the Local or the User folder. Selected presets are copied with a number appended to the name, which increments (just like the Auto Versioning option) so that no preset can be overwritten by mistake.

Show in Finder / Explorer: Opens a system window for the right-clicked file. In smart folders only, holding down an option key (Mac) or ctrl key (Windows) replaces this entry with Show in Browser, which shows the currently selected file in its original location in Repro-1’s browser.

Convert to native / h2p / h2p extended: Converts the selected preset(s) into the format previously selected by right-clicking on the [SAVE] button.

Copy / Paste: Clipboard functions. Individual or multiple presets can be copied then pasted elsewhere, even between Repro-1's browser and system windows (Finder, Explorer).

Move to Trash / Recycle Bin: Moves the selected preset(s) to the system trash.

[RESTORE] button

You can try out any number of presets without losing track of the one that was loaded immediately before you opened the browser. Clicking on the [RESTORE] button loads that preset and opens the enclosing folder.

Scan / Ready

In the top right of the presets panel is a dark rectangle normally labelled 'ready'. Whenever you use the refresh function (see the Directory context menu on the previous page), this turns into a progress indicator showing the preset database being refreshed.

Multiple selection

A block of presets can be selected via shift+click, and individual presets can be added via cmd-click (Mac) / alt+click (Windows). Presets can be moved to a different folder via drag & drop. To deselect, click on an unselected preset or choose *Deselect* from the context menu.

PRESET INFO

The area to the right displays information about the selected preset. If you can't see it, click on the triple bar [≡] button in the top right corner and tick *Show Preset Info*. Another option in the same menu lets you show or hide the tags only.

2-3 DRAG & DROP

You can drag and drop single or multiple files from the preset panel onto any folders in the directory panel. Files dragged onto regular folders will be moved unless you hold an **option** key (macOS) or **ctrl** key (Windows), in which case they will be copied instead. Files dropped onto smart folders will adopt the attribute of that folder: For instance, you can set the Author or Favourite status of several presets at once. See also [tagging using the Tags subfolders](#).

External Drag & Drop

To manage your preset library externally you can drag presets and folders between Repro-1's browser and your desktop (or any system window).

On the Mac most Finder operations will automatically update the browser. Updating might not be immediate when using multiple formats or multiple host applications, but all it usually takes is a click on the GUI or directory tree (sets focus to the clicked instance of Repro-1). On Windows systems, a manual *Refresh* (see [Directory context menu](#)) will be required before changes to the contents of the browser appear.

Another little helper: If you drag a Repro-1 preset from e.g. your desktop and drop it onto the Data Display, that preset will be loaded (but not automatically saved).

Exporting smart folders

Drag any smart folder onto the desktop to create a new folder containing those presets. Drag an entry from your Search History, or the Category 'FX', the Favourites or one of the Authors.

Exporting favourite / junk status

You can export Favourite status, all at once or individually: Shift+click and drag the 'Favourites' folder onto the desktop to create a file called *Favourites.uhe-fav*. Similarly for sub-folders: If you shift+click and drag e.g. 'Favourites 5', this will create a file called *Favourite 5.uhe-fav*. The same method works for Junk status, creating a file called *Junk.uhe-fav*. Such files can be imported into Repro-1's browser on a different computer (for instance), via drag & drop onto or anywhere within the Favourites folder, or to the Junk folder.

Note that importing .uhe-fav files from another computer will only work 100% correctly if all preset names and locations are identical on both computers!

Note for Windows users

According to Microsoft, drag & drop will only work between applications with the same rights (i.e. both admin or both normal) for security reasons. If the host was started using the "run as admin" option, drag & drop functionality will be limited: You can still drag objects between plug-ins, or from the plugin into system windows e.g. your desktop. However, attempts to drag & drop anything into the plugin from outside the host will fail. This applies to presets, folders, favourites, .uhe-soundset files or indeed anything that can be dropped onto the plug-in GUI.

2-4 INSTALLING SOUNDSETS

All soundsets we distribute ourselves will (eventually) be available in .uhe-soundset format. Third parties are also encouraged to use this package format for their own commercial soundsets – for details please contact our support team.

Standard Method

To install, drag & drop the .uhe-soundset file into Repro-1 – anywhere will work. The soundset should appear in the 'User' folder. If a soundset with the same name already exists there, any modified files will be backed up and the location of the backup file will be displayed.

Alternative Method

Soundsets in .uhe-soundset format can be installed by clicking on the u-he badge and selecting *Install Soundset...* from the menu. This option is especially useful for Linux, as the browser version for that platform does not support drag & drop.

Regular Folders

Folders containing Hive presets can be manually copied or moved into the 'User' folder. You might have to refresh the browser (see [Directory context menu](#)) before they appear there. A refresh is generally necessary in Windows but not in macOS.

Note: As .uhe-soundset files are basically ZIP-compressed folders, you can rename them i.e. replace the long file extension with '.zip' then extract everything in the usual way.

2-5 TAGGING

“Tags” are elements of metadata (information) you can add to presets so that they can be found according to certain attributes. See the image below.

IMPORTANT: Clicking on [SAVE] isn’t required, as tags are updated automatically. This makes editing tags much quicker overall, but also means that you should make a habit of adding tags **after you have saved your preset**, not while you are still editing them. Why? Because if you start changing the tags in the middle of creating a second version of a preset, you are also changing the tags in the original preset!

To set tags, you have a choice of three methods:

Standard method: Using the tagging window

Right-click on the [SAVE] button and select *Tag this Patch*:

CATEGORY

Bass	Acoustic
Pads	Analogue
Leads	Dist+LoFi
Keys	E-Bass
FX	FX Bass
Drums	Plucks
Seq+Arp	Rhythmic
Other	Sub
	Sync
	Synth
	Vocal

FEATURES

Mono	Slow Release
Chord	Glide
BPM	
OscSync	
CrossMod	
Dry	
Modulated	
Percussive	
Soft Attack	

CHARACTER

Bright	Dark
Constant	Moving
Clean	Dirty
Soft	Aggressive
Harmonic	Inharmonic
Phat	Thin
Natural	Synthetic
Modern	Vintage

CATEGORY describes a preset by analogy to instrument type or classic synth genre. Each category has its own set of subcategories. FEATURES are technical classifications, and CHARACTER tags are pairs of opposites from which you can choose only one.

Alternative 1: Using the PRESET INFO

In the PRESET INFO panel, right-click on CATEGORY, FEATURES or CHARACTER and select or unselect tags from the menu. Note: This method only works for individual presets. If you right-click on an existing tag, the first option in the menu becomes *remove tag 'xx'*.

The function *create Search from Tags* searches for presets with ALL those same tags.

Alternative 2: Using the Tags subfolders

You can drag & drop presets onto *Tags* smart folders e.g. *Tags/Categories/Keys/Bells/*.

To remove all tags from one or more presets, drag them onto the *[no Tags]* smart folder.

2-6 SEARCH BY TAGS

Click on the large TAGS tab to open this view. The buttons in this panel let you set up search criteria according to tags with just a few mouse clicks:

TAGS

Search

CATEGORIES ^

Bass	Pads	Leads	Keys	FX	Drums	Seq+Arp	Other
------	------	-------	------	----	-------	---------	-------

FEATURES ^

Mono	Chord	BPM	OscSync	CrossMod	Dry	Modulated
Percussive	Soft Attack	Slow Release	Glide			

CHARACTER ^

Bright	Dark	Constant	Moving	Clean	Dirty
Soft	Aggressive	Phat	Thin	Natural	Synthetic
Modern	Vintage				

FAVOURITES ^

○ 1	○ 2	○ 3	○ 4	○ 5	○ 6	○ 7	○ 8
-----	-----	-----	-----	-----	-----	-----	-----

There are four sets of buttons. The first three correspond to the tags in the tagging window (see the previous page), and the bottom row lets you search any ‘Favourites’. Click the [^] button on the right to collapse any of these tag types.

CATEGORIES and SUBCATEGORIES

Here are just a few bullet points to get you started. For this type of tag in particular, following a step-by-step tutorial is much easier than studying a full technical description. Try these:

- Each of the CATEGORIES has its own set of subcategories. Not selecting any subcategory here means “show me presets tagged **with any subcategory**”. Click on [Leads]...
- You can select multiple categories without specifying any subcategory if you hold **Cmd** (Mac) or **Ctrl** (Windows) while clicking on the category. Try that, click on [Keys].
- Selecting the subcategory with the same name as the category means “show me presets tagged **without a subcategory**”. You will not find any of these in the factory presets.
- Completed category+subcategory tags appear below the subcategories as buttons with ‘off’ switches [X] so you can add other main categories by simply clicking on them.

Practical tutorial

- Click on the **DIRECTORY** tab, right-click on the *Search History* smart folder and select *clear*. Double-click on *Local/02 Leads* to restrict the scope of the search to that particular folder. The selected path */Local/02 Leads* appears below the Search field instead of preset folders.
- Click on the **TAGS** tab. In the CATEGORIES, select [Bass]. Subcategory buttons appear and the preset window is updated to list all presets in *02 Leads* that are also tagged as [Bass].
- Now click on [Pads]. The [Bass] category is switched off, and the preset window is updated to list all the presets in *02 Leads* that are also tagged as any kind of [Pads]. Note that you still haven't specified a subcategory yet...
- Hold **Cmd** (Mac) or **Ctrl** (Win) and select the [Bass] category again. Although no longer outlined, the previously selected [Pads] remains highlighted and the list shows all presets in *02 Leads* that have either of those tags, disregarding any subcategories.
- Click on **DIRECTORY**: The text **#Bass:* #Pads:*** appears in the editable field as well as in the *Search History* smart folder (see section [2-9](#)), which also shows the number of found presets. The colon separates the category from the subcategory, and the star (*) means "any subcategory, even none".
- Click on the **TAGS** tab again. Select the [Leads] category **without** holding down Cmd/Ctrl this time... the [Bass] and [Pads] tags are both removed from the search. Select [Sync] as subcategory. The result is a list of all 16 presets in *02 Leads* that have the Leads:Sync tag. Below the subcategory options you will see the complete tag in the form **[Category:Subcategory|X]**.
- Let's get more hits by including another subcategory: Click on the [Distorted] subcategory. [Sync] remains selected, and the list of hits is updated to include presets which have **either** of those tags i.e. 28 in total. Click on [Sync] and the tag search will find only 17 presets – all those that are tagged as [Leads:Distorted].
- Click the [Bass] category. Below the subcategories, the [Leads:Distorted|X] switch remains in place because that tag is complete. Check out the category tags in PRESET INFO by clicking on several presets in turn: Each one will have either a Leads:Distorted tag or a Bass tag (disregarding subcategory) or both.
- Click on the **DIRECTORY** tab. The text **#Bass:* #Leads:Distorted** appears in the search field as well as the *Search History* smart folder. If you are feeling adventurous, you can edit this and the results will be updated accordingly.
- To the left of the grey search path is an 'up' [^] symbol. Click on this to exit the current folder i.e. change the search path from */Local/02 Leads* to the */Local* root. The list of hits is immediately updated to 193 presets because the search now includes all of */Local*.
- Another click on [^] exits to the whole preset library i.e. */Local and /User*. Clicking on the [X] symbol to the right of the search path will exit immediately. Try that.

Repeat the above a few times if necessary – you'll soon get the hang of it!

FEATURES, CHARACTER and FAVOURITES

These types of tags are much easier to explain. Unlike multiple Category tags, which **expand** the search, selecting these Tag types always **restrict** the search. For example, let's find the few *inharmonic sequences* in the entire preset library, irrespective of category:

- If any CATEGORIES are still highlighted, click on them.
- Select FEATURES = [Seq] and CHARACTER = [Inharmonic]. That's it.

Summary:

In the DIRECTORY panel, specify a search path via double-click. In the TAGS panel, select category tags. Add others if required to extend the search, but remember to hold down Cmd (Mac) or Ctrl (Windows) if you want to retain category tags that don't specify a subcategory. Select Features, Character and/or Favourites tags to refine the search. Exit any search path by clicking on the [X] to the right.

2-7 SEARCH BY TEXT

The editable field immediately below the DIRECTORY and TAGS tabs lets you search for presets according to a string of characters i.e. text. The search normally looks into the preset name, the author, the DESCRIPTION and USAGE (see the PRESET INFO panel). It is not case-sensitive. Quotes are not required unless you need to include spaces.

If you want to restrict the search to a particular path e.g. *Local/05 Percussion*, double click on the *05 Percussion* folder. This path then appears below the Search field, and you will only see smart folders plus any subfolders within the selected path (there are none in this example):

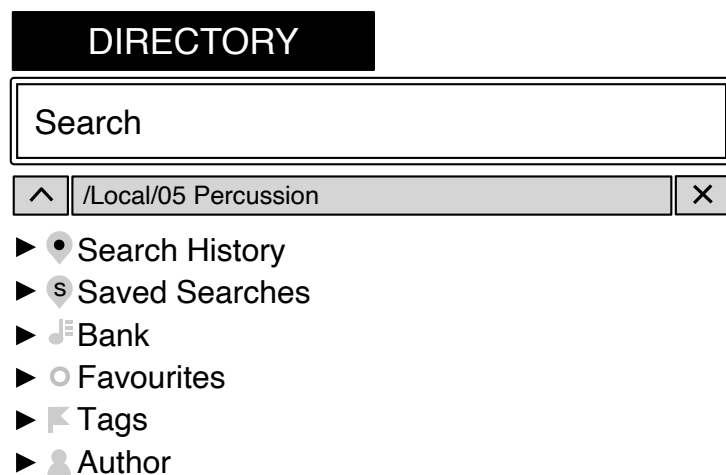

The [^] button to the left moves the search path up one level, in this case to */Local*. The [X] button to the right sets the search path to the default *Local* and *User* (i.e. all *Repro-1* presets), and the preset folders become visible again. Alternatively, you can navigate directly to any higher level by right-clicking on the path.

Try a text search: Enter three or four letters then hit Return. For instance, *star* will find all files containing the text string *star* (e.g. *mustard* or *starters*). Entering "*star wars*" (with the quotes) would find e.g. *Battlestar Warship*, if such a string existed in the presets.

Scope

You can limit the scope of the search to just the preset name or specific parts of PRESET INFO by using **name** (preset name), **author**, **desc** (description) or **use** (usage) followed by a colon. For instance, *author:the* finds all presets by sound designers whose author names contain 'the'. Similarly, *desc:space* will find all presets with the word *space* in the description.

Logic

Important: The following logical operators can only be used between text elements.

AND requires that presets contain both words. It can be written explicitly if you prefer, but is not necessary. For example, *star AND wars* (or simply *star wars*) will find presets that contain both *star* and *wars*.

OR means that presets can contain just one of the words, or both. For example, *star OR wars* will find presets that contain *star* as well as presets that contain *wars*.

NOT excludes presets containing the word. To find all presets that contain *star* but don't contain *wars*, enter *star NOT wars*.

Written Tags

Regular tags can also be entered into the search field if preceded with a '#'. For example, *name:"hs " #bass:** will find all presets with "hs " in the name that are tagged as *Bass* with any or no subcategory. The colon separates category and subcategory, and the star (*) means "any subcategory, even none". Between multiple tags of the same type is an implicit OR, while between different types is an implicit AND.

Note: In the current version of the browser, tags must appear after any text items!

A few example searches

Try copy/pasting these into Repro-1's search field:

desc:classic

author:ark

use:"at =" author:sc

usage:"bc ="

*"hs " OR xen #leads:**

tuc NOT "mw ="

ark OR howard #bass:wobble = all ARK plus HS wobble basses

ark OR NOT how #bass:wobble = all ARK plus non-HS wobble basses

2-8 SMART FOLDERS

Smart folders do not contain files, they display the results of querying a database of all presets. The content is therefore dynamic i.e. it will change whenever the underlying data changes.

Search History

Click on this folder to display the results of past searches (maximum 10). Whenever you need to make the results of a search more permanent, right-click and select *Save Search...* The entry will be moved to the 'Saved Searches' folder – see below.

To remove all searches from the list, right-click on the 'Search History' folder and select *clear*. Note: Individual entries cannot be removed here, unlike 'Saved Searches'...

Saved Searches

This folder contains searches that have been saved via right click from 'Search History'. To remove individual saved searches, right-click on the search and select *Delete*.

An entry dragged from 'Saved Searches' and dropped onto a normal folder within 'Local' or 'User' will create a folder containing real copies of all the found presets.

Favourites

8 smart folders, one for each Favourite colour. See [Presets context menu](#). Presets dropped onto one of the Favourites folders will be marked as such.

Junk

A smart folder pointing to all junked presets. See [Presets context menu](#). Presets dropped onto this folder will be junked, and will therefore disappear from the rest of the browser unless made visible (see *show junk* in the [Presets context menu](#)).

Tags

Smart folders for each *Category/Subcategory*, *Features* and *Character* tag. Presets dropped onto these folders will adopt the corresponding tag. Presets dropped onto the *[no Tags]* folder will have all *Category/Subcategory*, *Features* and *Character* tags removed.

Author

Smart folders for each *Author*. Tip: Instead of signing each of your creations, you could sign just one of them, then select them all and drag them onto *Author/(You)/*. As the process cannot be undone, you should use this feature with caution.

3 SYNTH

3-0 OVERVIEW

This section explains the various modules available on Repr0-1's SYNTH panel. If you don't see this panel, click on the SYNTH button at the top left of Repr0-1's window.

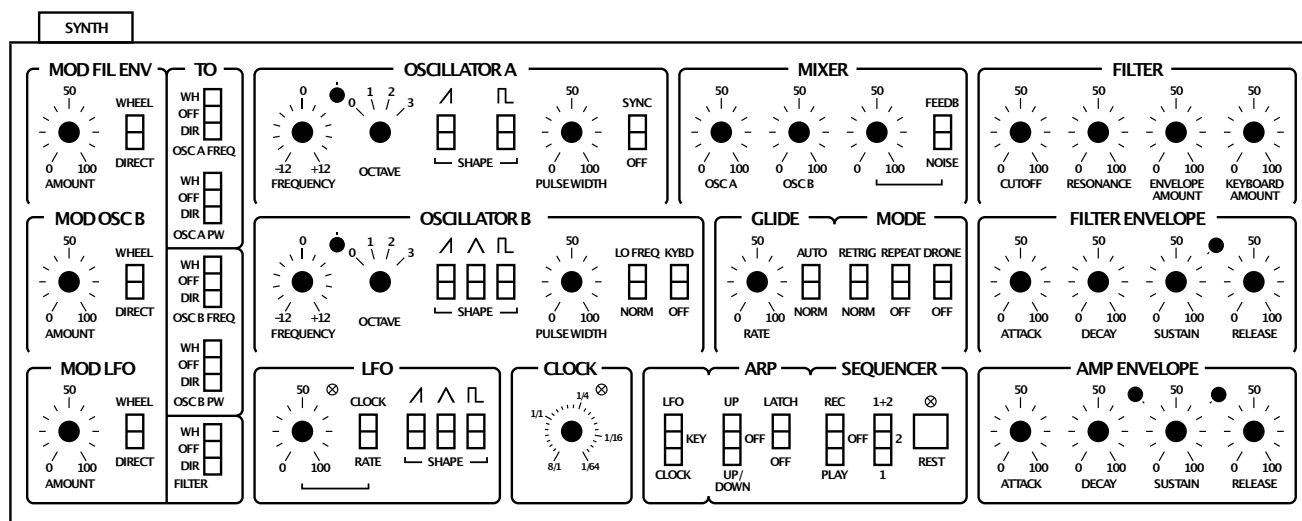

The PRESETS browser is described in the previous chapter, while the TWEAKS page and SEQUENCER functions are described in separate chapters later in this guide.

Due to its relatively simple architecture, you *can* operate Repr0-1 without having to think about its structure. However, if you want to make the most of the available options, it's best to understand how signals are routed between those modules...

3-1 VOICE SIGNAL FLOW

On the next page is a flow diagram showing the audio signal paths as well as some keyboard control paths – you might like to print it out for future reference. A similar diagram showing modulation signal paths appears later in this chapter.

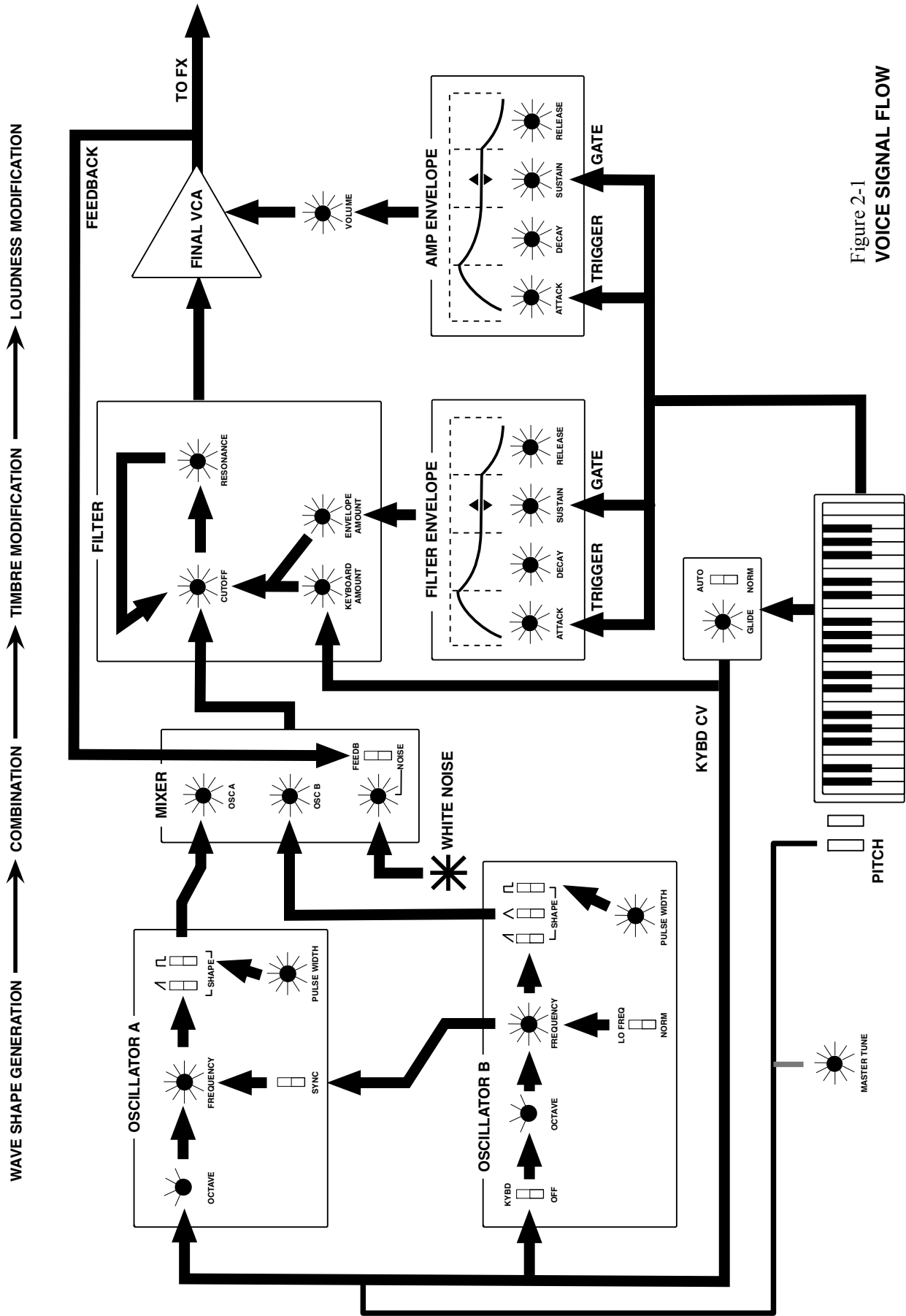
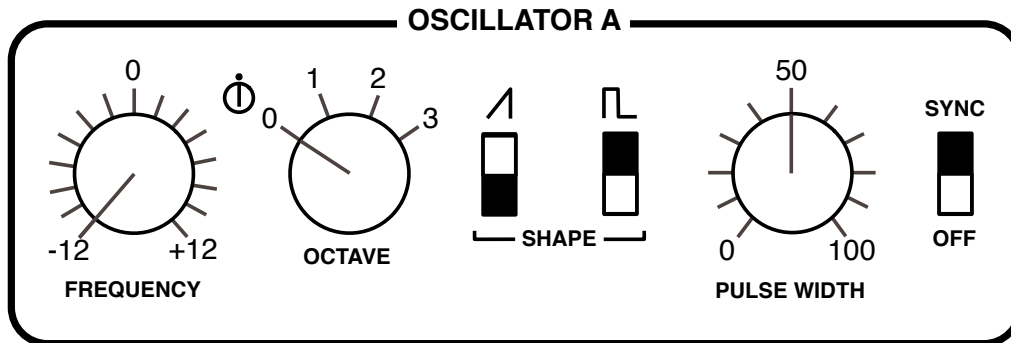

Figure 2-1
VOICE SIGNAL FLOW

3-2 OSCILLATOR A



FREQUENCY knob: Adjusts pitch within a two-octave range (+/- 12 semitones).

FINE TUNING trimmer between FREQUENCY and OCTAVE: Adjusts pitch within a 40 cent range (+/- 20 cents). Its main purpose is to adjust the rate of beating between the two oscillators when they are tuned almost in unison.

OCTAVE rotary switch: Transposes oscillator pitch over a four-octave range.

SAWTOOTH SHAPE switch: The UP position activates the standard brassy waveform containing all harmonics (odd as well as even).

PULSE SHAPE switch: The ‘up’ position enables a waveform with a harmonic content that depends on the PULSE WIDTH setting but sounds generally more hollow than the sawtooth. If neither SHAPE is switched on, OSCILLATOR A is silent. If both SHAPES are active, the mixture normally has a lower volume than each single shape due to the phase relationship between the saw and pulse. To remedy this effect, set the *P5* option (see [Oscillator Tweaks](#) on page 31).

PULSE WIDTH knob: Adjusts the harmonic content of the pulse wave by setting its “duty cycle”. The range is from 0% to 100%. Double-click on the knob for a 50% pulse (a clean square wave which only contains odd-integer harmonics).

Notes: At extreme values, the signal gets so thin that it becomes inaudible (DC, direct current). The PULSE WIDTH knob has no effect on the sawtooth.

SYNC switch: Hard synchronization forces the waveform of OSC A to reset whenever OSC B hits zero. The frequency of OSC A generally needs to be higher than OSC B for this to work properly. Experiment: Intermediate FREQUENCY values can produce unusual timbres at the next lower harmonic of OSC B.

3-3 OSCILLATOR B

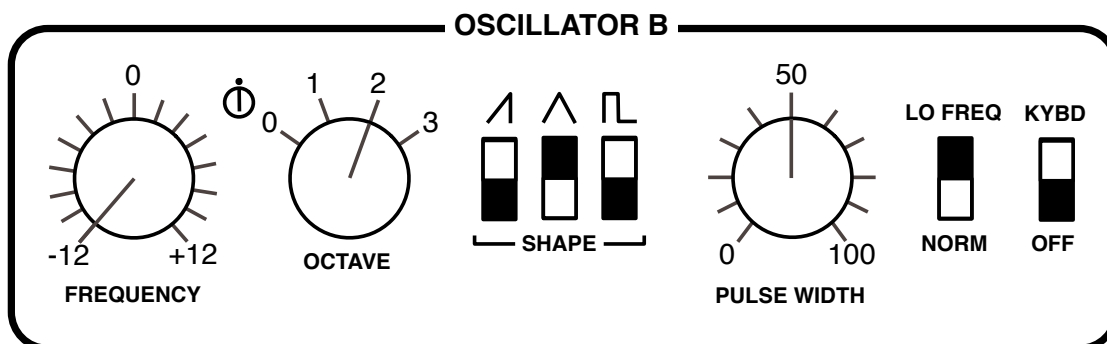

OSC B is basically the same as OSC A – without SYNC but with the following extras:

TRIANGLE SHAPE switch: This waveform is bipolar, so it doesn't add any DC to the modulation when used as an LFO. As an audio signal, the triangle has very little bite, but can be used to boost the fundamental frequency. The triangle is also good for driving the *wavefolder* effect (see EFFECTS chapter).

NORM | LO FREQ switch: Extends the range of oscillator B down to sub-audio frequencies suitable for use as an LFO. Note that the FREQUENCY range is 4 times greater than in NORM mode.

KYBD | OFF switch: Switching this to OFF disables keyboard follow, resulting in a constant pitch independent of the played note.

3-4 GLIDE & MODE

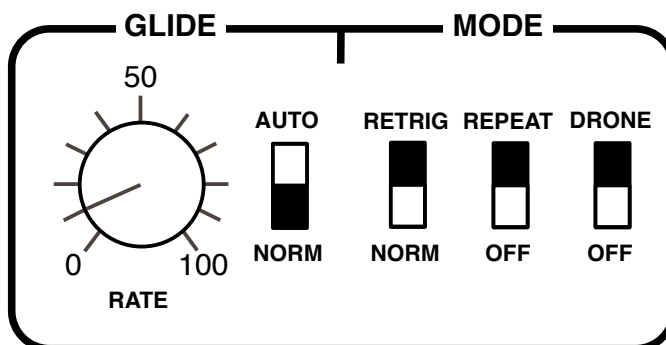

Also known as 'portamento', **glide** is the slurring of pitch between consecutive notes.

RATE knob: How long it takes to move from one note to the next. At zero, pitch changes are instantaneous, while they are very slow at values above 50.

AUTO switch: In the NORM position, all notes will glide. In the AUTO position, this only happens when a new key is hit while the previous one is still being held (**legato**).

RETRIG switch: In the NORM position, legato playing does not retrigger envelopes. In the RETRIG position, the envelopes are retriggered with each new note.

REPEAT switch: Retrigger the envelopes at the rate of either the LFO or the Clock, depending on the state of the LFO|KEY|CLOCK switch. Like in the hardware and in DRONE mode, notes repeat without you having to hold down a key...

DRONE switch: Keeps the AMP ENVELOPE sustaining indefinitely.

3-5 MIXER

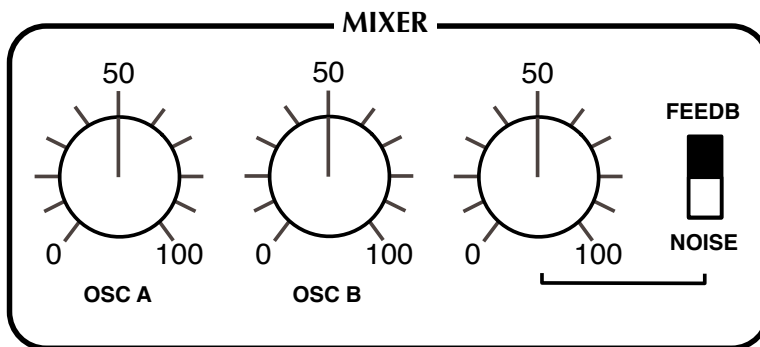

OSC A and **OSC B** knobs: The output levels of each oscillator.

FEEDB | NOISE knob and switch: With the switch in the NOISE position, the knob sets the output level of the noise generator (an unpitched audio source useful for wind and percussion effects etc.). With the switch in the FEEDB (feedback) position, the knob governs the amount of signal fed *from behind the amplifier* back into the MIXER (use this for e.g. bass boost).

3-6 FILTER

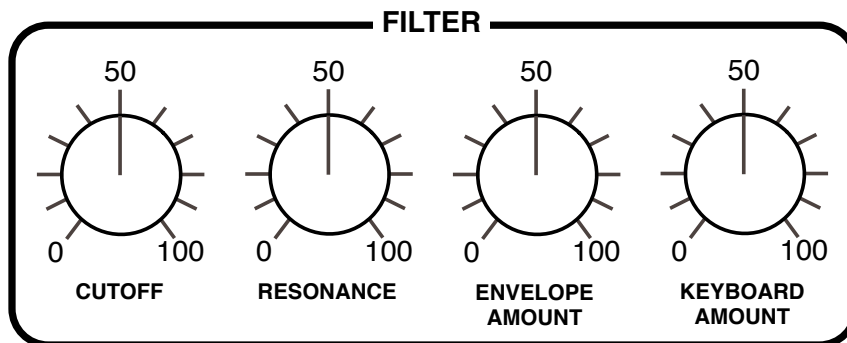

CUTOFF knob: Sets the cutoff frequency for the 24 db/octave (4-pole) lowpass filter, which works a bit like a tone control. The “Cutoff” point is the frequency below which all components of a signal are allowed to pass, while most of the higher frequency components are suppressed.

RESONANCE knob: Determines the amount of feedback within the filter circuit. The higher the resonance, the more the cutoff point will be accentuated. Somewhere above 60 the filter starts to self-oscillate – it becomes a sine-wave oscillator with pitch determined by the cutoff. Note that adding Resonance tends to lower the volume, in which case you should compensate by e.g. turning up the main OUTPUT.

ENVELOPE AMOUNT knob: Adjusts the amount of cutoff modulation from the filter envelope (see below).

KEYBOARD AMOUNT knob: The amount of cutoff modulation from the keyboard – the higher the note, the higher the cutoff. Set to precisely 75.00, cutoff follows notes almost perfectly.

3-7 FILTER ENVELOPE

The filter envelope generator applies a contour to the cutoff frequency:

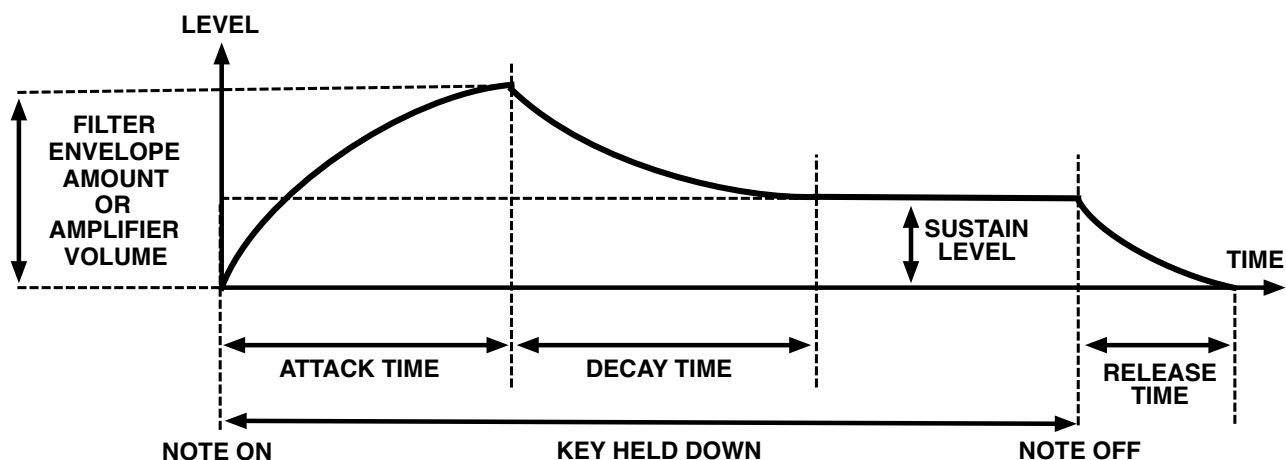

The envelopes are started whenever a note is played, and as long as the key is held down, the envelope proceeds through the ATTACK and DECAY stages. It then remains at the SUSTAIN level until the key is released, after which it drops to zero at a rate set by the RELEASE knob.

Note: The RELEASE stage is initiated as soon as all keys are released. If this happens during the ATTACK or DECAY, there is no SUSTAIN stage.

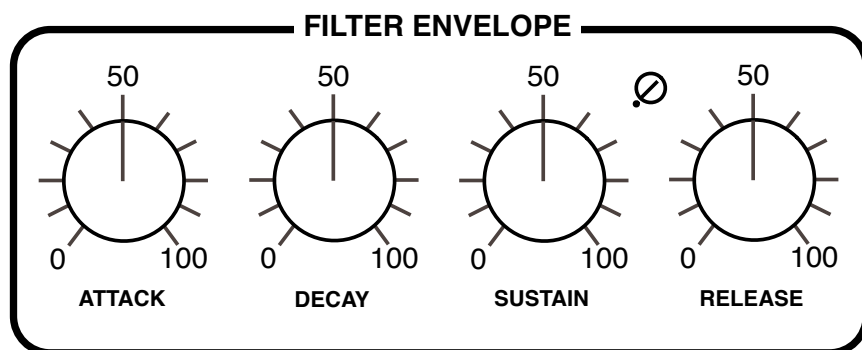

ATTACK knob: Varies the time for the envelope to rise from zero to maximum, within a range of 2 milliseconds to longer than 6 seconds.

DECAY knob: Varies the time for the envelope to fall from maximum to the SUSTAIN level, also within a range of 2 milliseconds to more than 6 seconds.

SUSTAIN knob: The “hold” level, from zero to maximum. An interesting detail: While being adjusted, SUSTAIN always *decays* to the new level – the longer the DECAY, the longer it takes to reach the new SUSTAIN setting.

RELEASE knob: The time it takes to fall from the current level (usually SUSTAIN) down to zero after the key is released. The range is 2 ms to longer than 6 seconds.

Velocity Trimmer: The control between SUSTAIN and RELEASE effectively multiplies ENVELOPE AMOUNT (see above) with note velocity. If the trimmer is set to maximum, **minimum** velocity will reduce the amount of modulation to zero.

3-8 AMP ENVELOPE

The AMP ENVELOPE controls shape the envelope applied to volume, pre-effects.

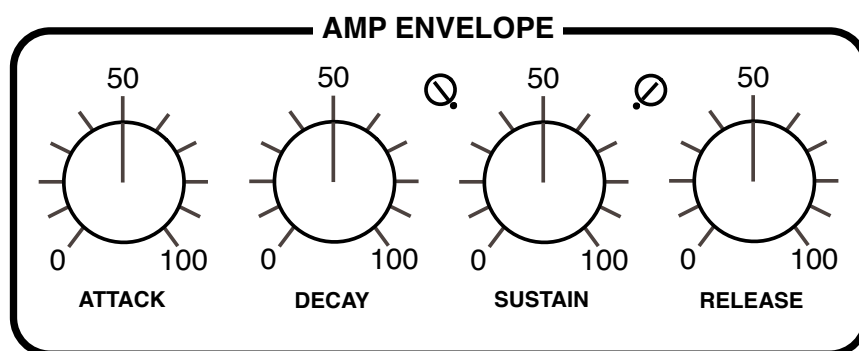

Volume Curve trimmer: In the original hardware, the VOLUME knob controls how much amp envelope modulates the final VCA. It also affects the envelope **curvature** – not by design, but as a side-effect of how it works. As *Repro-1*'s equivalent **OUTPUT** knob comes after all effects, the only way to implement this quirk was as a separate control – the trimmer between DECAY and SUSTAIN.

Here is how the attack and decay stages appear when *Volume Curve* is set to zero and 100. Note the punchy *s-curve* and shorter decay at minimum *Volume Curve*:

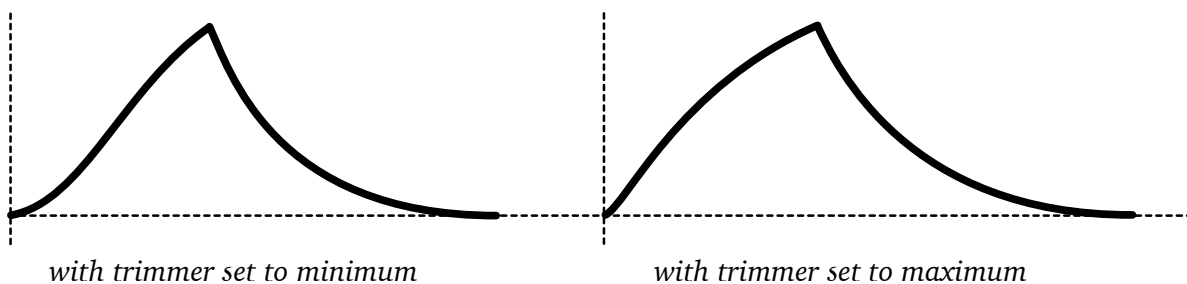

Velocity Trimmer: The trimmer between SUSTAIN and RELEASE adjusts the amount of velocity modulation for the amp envelope. When set to maximum, **minimum** MIDI velocity will reduce the envelope level to zero i.e. silence.

3-9 LFO

Two of the modulation sources – the filter envelope generator and oscillator B – are described above. The third source is the Low Frequency Oscillator (LFO):

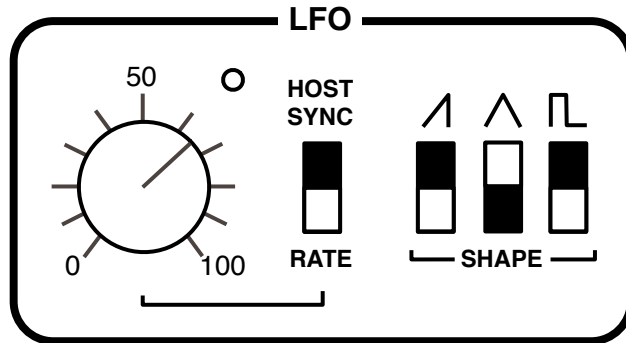

CLOCK | RATE switch: When set to **CLOCK**, the LFO follows the Clock setting (see page 26). The **RATE** option here allows LFO speed to be freely adjustable via the **RATE** knob...

RATE knob: Adjusts LFO speed within a range of about 0.1Hz to 30Hz.

SHAPE switches: The same options as in **OSC B** except that the LFO's pulse width is fixed at 50%. Remember that you can add the shapes here e.g. **SAW + SQUARE**.

3-10 MODULATION SECTION

Repro-1 offers three modulation sources which can be mixed and routed through two different paths to five modulation targets:

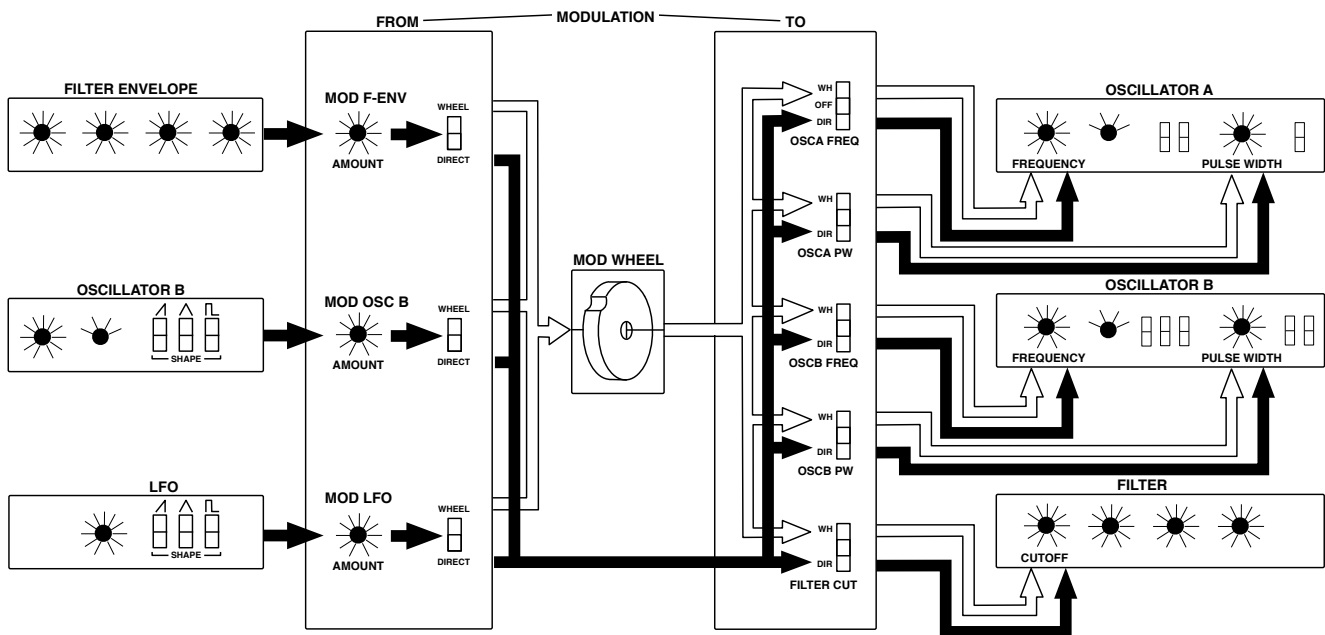
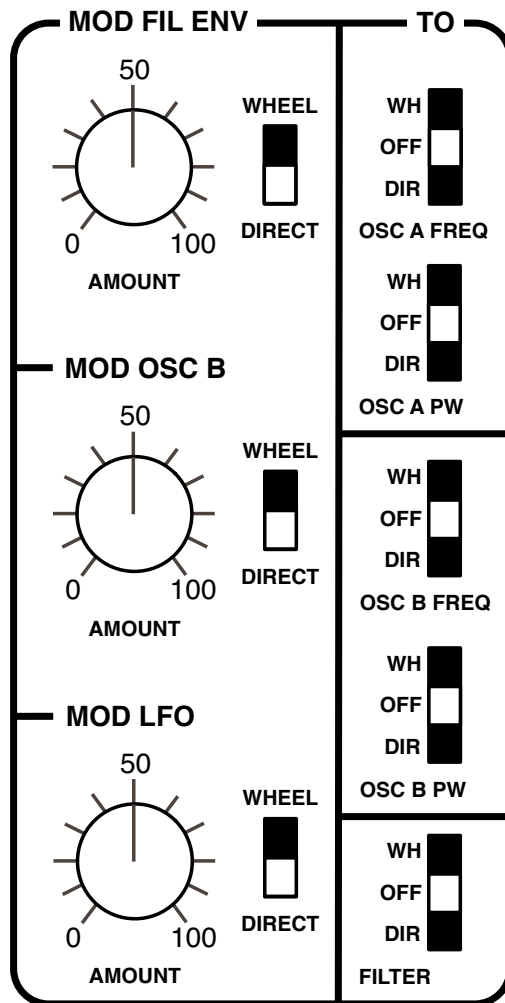

Figure 2-10
MODULATION SIGNAL FLOW

This panel is the one most likely to confuse beginners. After a few hours practice, however, it should become second nature – especially if you repeat this mantra:

“ 3 sources via 2 paths to 5 destinations ”



MOD FIL ENV, MOD OSC B and MOD LFO knobs: The amount of modulation mixed into the WHEEL or DIRECT paths. The depth of modulation routed into the WHEEL path is controlled by the modulation wheel (MIDI CC#01).

WHEEL | DIRECT switches: These route each of the 3 sources into one of two busses: the so-called WHEEL or DIRECT paths.

OSC A FREQ, OSC A PW, OSC B FREQ, OSC B PW, and FILTER switches: The vertical row of switches select either the WHEEL or DIRECT path for each destination.

Note: In the original hardware the signal at each PW input gets inverted – when the modulating signal goes up, the pulse width goes down. We decided to keep this quirk, so if you want to compensate for deep modulation by adjusting PULSE WIDTH, you need to compensate in what seems to be the wrong direction!

Modulation Section – Practical Examples

LFO vibrato via modulation wheel

Load the -INIT- preset and turn OSC B down to minimum in the MIXER section. Turn MOD LFO amount in the modulation section up to about 20% and switch its output to the WHEEL path. In the TO column, select WH (wheel) as modulation input for OSC A FREQ (the uppermost switch). In the LFO panel, adjust the RATE knob to about 75.

We now have vibrato via mod wheel – try it. Lets add something else...

Sync sweep

Switch oscillator A SYNC on. Push the mod wheel – vibrato has become oddly shallow because oscillator A is “trying” to adopt the same pitch as oscillator B. In the TO column, select WH (wheel) as input for OSC B FREQ (the central switch). Vibrato is now back to normal.

Turn MOD FIL ENV amount up to maximum. The MOD FILE ENV output is set to the DIRECT bus, which is what we want here. Now switch OSC A FREQ source to DIR (direct). Turn the filter envelope SUSTAIN level down to minimum and increase the DECAY until the sweep effect sounds good.

LFO pulse width modulation (PWM)

Click on the data display and reload -INIT-. In the MIXER section, turn OSC B down to minimum. In oscillator A, switch the sawtooth off and the pulse on. Turn MOD LFO amount up to maximum. Its output is already set to the DIRECT bus – in the TO column, select DIR as modulation input for OSC A PW (the second switch from the top)...

Filter-FM

Turn MOD OSC B up to maximum and route it to WHEEL. In the TO column, select WH as modulation input for FILTER (the bottom switch). In the FILTER section, turn CUTOFF down to about 50. Push your modulation wheel and experiment with all the controls in oscillator B.

3-11 CLOCK

So that the LFO, arpeggiator and sequencer can be synchronized, we need a 'clock'...

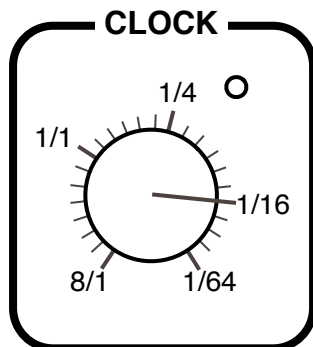

This little panel contains a single rotary switch which sets the clock speed relative to host tempo, plus an indicator. All values are expressed as 4/4 bar divisions from 8/1 (slowest) to 1/64 (fastest).

The *trip* options are **triplets** (3 in the space of 2) and the *dot* options are **dotted** (2 in the space of 3 i.e. 50% longer than normal):

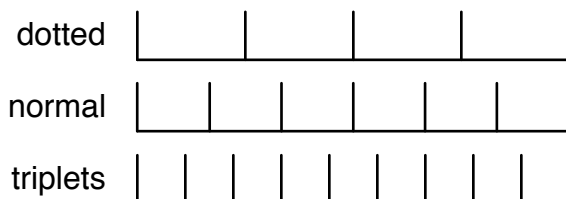

The order of values may appear strange at first (e.g. 1/4 then 1/8 dot then 1/4 trip), but you can rest assured that they have been sorted according to length.

3-12 ARP / SEQUENCER (basic access)

An arpeggiator plays back all held notes, one after the other.

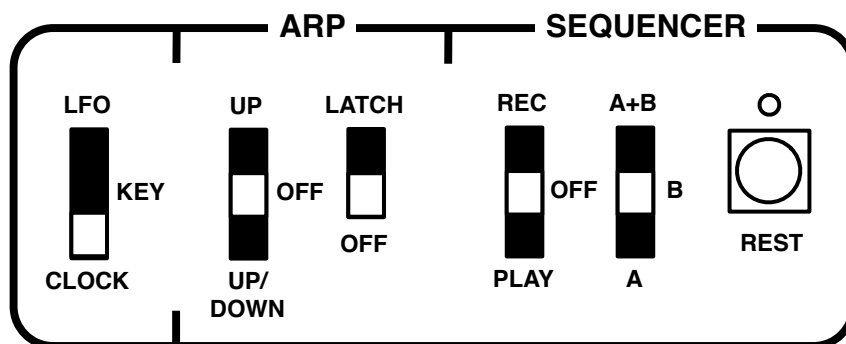

LFO | KEY | CLOCK switch: This switch selects which signal will be used to drive the arpeggiator, sequencer and REPEAT function. In the **CLOCK** position they are all synchronized to host tempo via the **CLOCK** parameter (see the previous page), while in the **LFO** position they are synchronized to the LFO. With the **KEY** option, the sequence is played back one note per key-press (see **Design decisions** below).

UP | OFF | UP/DOWN switch: Activates the arpeggiator, either upwards only or upwards followed by downwards.

LATCH switch: The **LATCH** function in the original hardware (mis)used the sequencer memory. **Repro-1** has a dedicated **LATCH** switch instead – try this:

While you are playing an arpeggio, slide the **LATCH** switch up. Take your hands off the keys and try adding some more notes. It will soon become apparent that these notes are temporary – they disappear as soon as you release them, while the latched notes continue.

Note: The **SEQUENCER** part of this panel contains just enough elements to let you record and play back sequences without switching pages. For the complete story, please read the next chapter.

Design decisions

In the original hardware, the arpeggiator/ sequencer rate is permanently tied to the LFO, with the option of using an external trigger signal to advance the arp/sequencer instead. As we don't expect users to feed an external trigger into **Repro-1** just for the sake of authenticity, we decided to add a host-synced **CLOCK** and use **MIDI NoteOn** messages for the 'step through' option.

Here's an interesting quirk: The arpeggiator will not repeatedly trigger a single held note – you have to play at least two notes for arpeggiation to start!

4 SEQUENCER

4-0 INTRODUCTION

The sequencer in the original hardware may have been a minor stroke of genius, but these days we can expect something a bit more comfortable: *Repro-1's* sequencer lets you *step-record* two patterns of up to 32 notes each (they are saved with the preset):

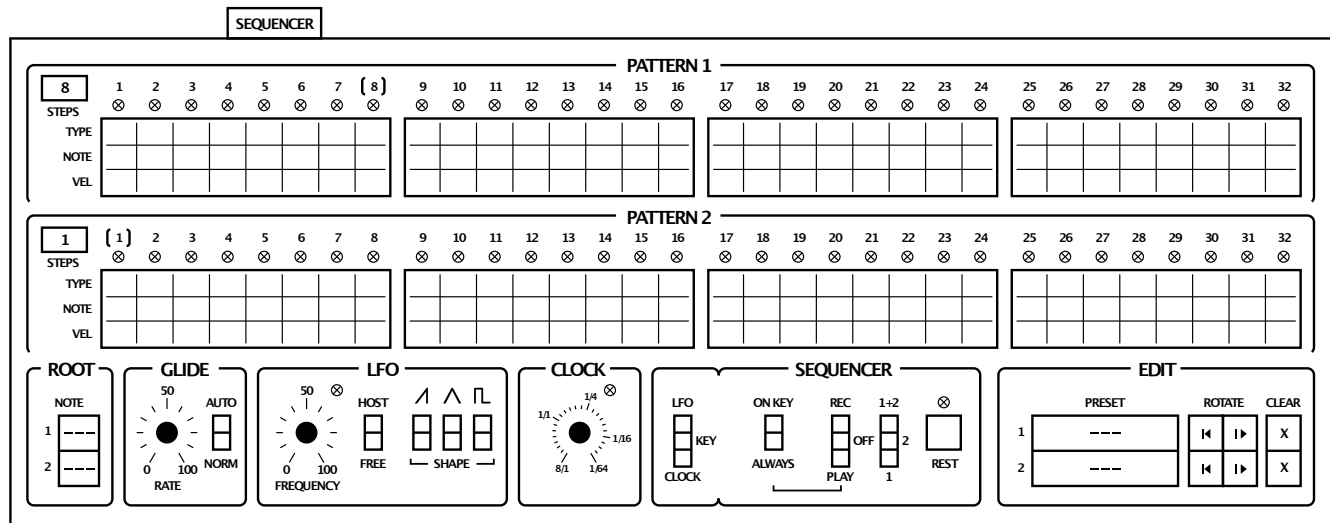

How to record: In the SEQUENCER sub-panel, select a pattern (1, 2, or 1+2) and slide REC/PLAY up to the REC position. Play some notes, inserting pauses by clicking on the REST button. The pattern can be as short as you like, even a single note – simply switch from RECORD to PLAY whenever you're finished.

How a sequence plays back is governed by the Clock settings (see the next page). Playing any note other than the specified ROOT transposes the pattern up or down.

Host buffer size: *Repro-1's* sequencer works best with a buffer size of at least 128 samples (most DAWs set larger buffer sizes by default). This doesn't mean it won't work with smaller buffers, but we did experience one or two glitches in certain hosts.

4-1 PATTERN data

A sequence consists of two patterns containing up to 32 steps each.

STEPS selectors: These specify the length of each sequence i.e. the number of steps to play before returning to step 1. Alternatively, click on one of the indices (1 to 32).

TYPE cells: Either click on a cell or use the mouse wheel to cycle between regular note (a filled circle), tied note (an arc) or pause (a faint 'X'). Perhaps unusually, a tied note extends its gate to the next note, not from the previous one.

NOTE cells: Semitone offsets from -36 (3 octaves down) to +36 (3 octaves up).

VEL cells: MIDI velocity data, from 1 to 127 (the default is 90). While the sequencer is running, this data is used instead of any other velocity source (e.g. from notes played on your keyboard).

ROOT selectors: These define NOTE '0' – the note set here will play the sequence at the same pitch as it was recorded. A lower ROOT actually transposes the sequence *upwards*, which is counterintuitive but logical.

Note: By default, the *Root* is automatically set to the first recorded note. This can be switched off – see the **Sequencer Root Note** option in the Preferences page.

4-2 SEQUENCER control

This panel is the same as the one on the SYNTH page, but without the arpeggiator:

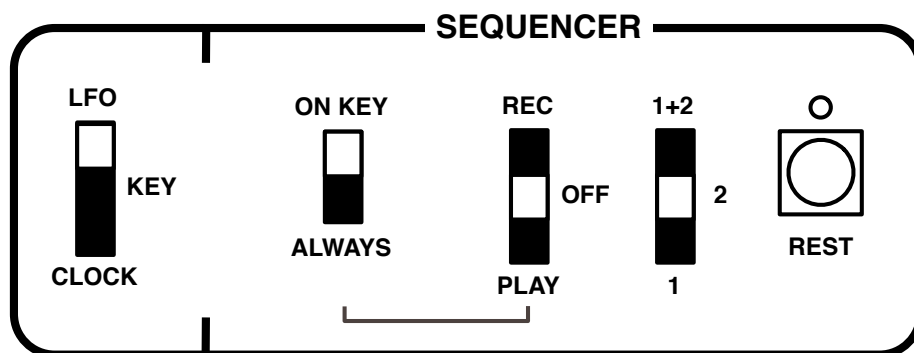

LFO | KEY | CLOCK switch: Selects which signal will be used to drive the arpeggiator and sequencer. In the **CLOCK** position they are both synchronized to host tempo, while in the **LFO** position they are synchronized to the LFO. With the **KEY** option, the sequence is played back one note per key-press.

ON KEY | ALWAYS switch: The **ALWAYS** option causes the sequence to continue playing even if all keys are released (simulating a hold pedal). **ON KEY** stops the sequence as soon as all keys are released, restarting it when a new key is pressed. Please note that this switch is global per instance of the plug-in: the status doesn't change, even when you load a different preset.

REC | OFF | PLAY switch: Primes the sequencer for recording. Recording commences when you play the next note and stops when you switch to **OFF** or **play**. Recording also stops automatically when step 32 has been reached (if the next selector is set to 1+2, it will only stop at step 32 of pattern 2).

1+2 | 2 | 1 switch: Selects the pattern(s) to be recorded or played back.

REST button: During recording, this inserts a pause at the current step.

4-3 EDIT

This panel gives you some tools with which you can manipulate the pattern data...

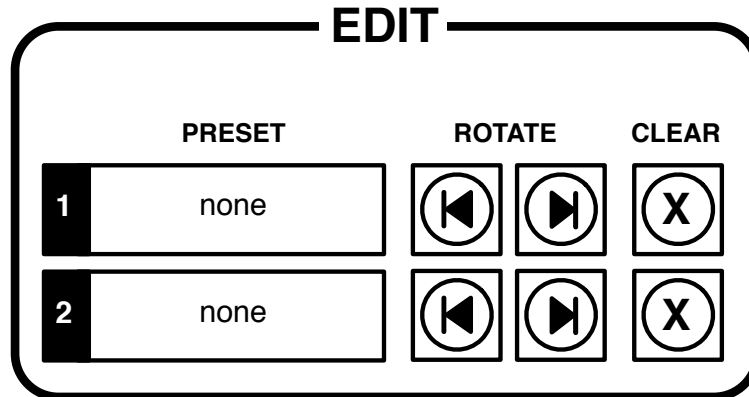

PRESET selectors: Click to open a menu containing pattern *Copy* and *Save* functions, as well as any sequencer patterns Repro-1 finds in the following location:

Win ... \VstPlugins\u-he\Repro-1.data\Support\Modules\Pattern
Mac MacHD/Library/Application Support/u-he/Repro-1/Modules/Pattern

ROTATE buttons: This pair of buttons shifts the active portion of the sequence to the left or right. If, after listening for a while, step 1 doesn't seem to be the 'first note', you can use the Rotate buttons to fix that problem. Tip: Create new variations by rotating parts of existing sequences.

COPY and **PASTE** buttons: Clipboard functions for each pattern. Note that you can copy from one preset and paste into another.

CLEAR buttons: Deletes all data in the pattern and sets the current step to the start.

4-4 A FEW TRICKS

Start a sequence that contains ties as well as rests, then go to the SYNTH page and try performing with your sequence using only the MODE switches:

Switching on RETRIGGER transforms ties into regular notes.

Switching on REPEAT effectively removes rests. It doesn't use the pitch data, however, but repeats the pitch of the note immediately preceding the rest.

Switching on DRONE will lengthen the notes if amplifier Sustain is turned up, or the Decay time is longer than the Release time. Experiment!

5 KEYS / MOD MATRIX

The pair of vertical buttons on the bottom left select either the EFFECTS view or the KEYS view (which also includes a little modulation matrix called PERFORM - see the next page):

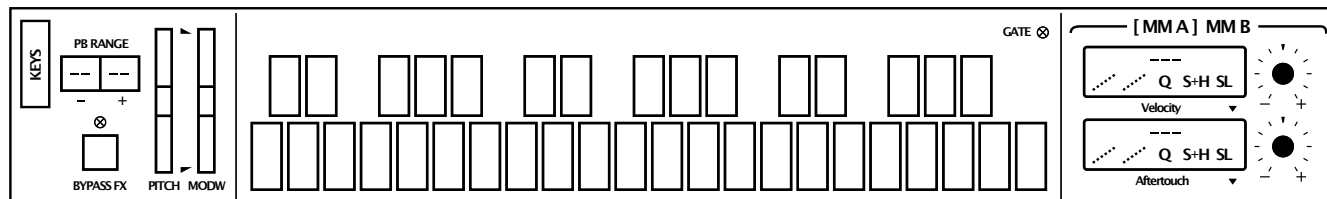

5-0 KEYS

Between those vertical buttons and the keyboard are a few typical 'left-hand controls'...

PB RANGE selectors: You can choose pitchbend ranges separately for each direction (down and up). The options are 0 through 24 (2 octaves in semitone steps) then 3 or 4 octaves (36 or 48 semitones).

BYPASS FX switch: Below PB RANGE is an effects bypass button you should find useful for comparing the treated and untreated sound. Please note that BYPASS FX is truly global: the status doesn't change, even when you load a different preset.

PITCH and **MODW**: The two on-screen wheels mirror incoming MIDI data, but you can also adjust them with the mouse like any other controls in Repro-1.

To the left of the modulation wheel (MOD) is a pair triangles which set the upper and lower limits for modulation via the WHEEL path – click and drag vertically. Note that these elements are modulation targets (in the MIDI submenu).

KEY CTRL gives the two elements a common focus, but if your current host setup allows, you can select the individual controls by typing U (upper) or L (lower), or via option+cursor (Mac) / ctrl+cursor (Win). Also, S (scroll) should select both limits so they can be adjusted in parallel, and the Backspace key resets to the default maximum/minimum positions. These features are clunky, but please remember that KEY CTRL is "work in progress".

Keyboard: Most of the panel is taken up by a 3-octave touchplate-style keyboard (the same range as the original synth) you can click on to fire off notes. Double-click on a key to sustain it until you click on another.

A note to users of **3-octave MIDI keyboards**: You might have to transpose your keyboard down an octave to match the range of Repro-1's touchplate.

5-1 MODULATION MATRIX (MM)

To the right of the keyboard in [KEYS](#) view is a 4-slot modulation matrix you can use to extend Repr0-1's modulation capabilities. If you need more than 2 slots, switch to MM B.

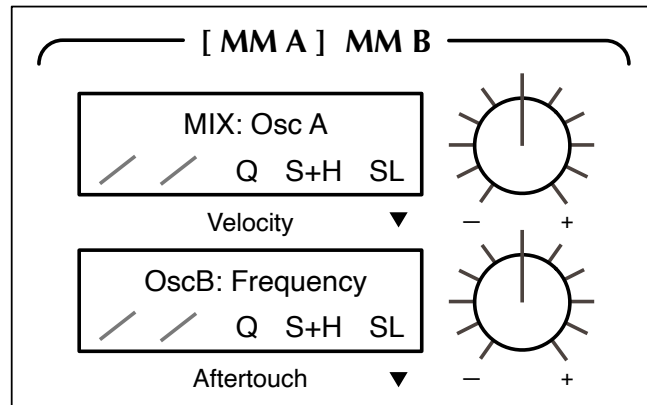

To select a **source**, click on the label below the target selector (e.g. where it says 'Velocity' in this image). Note that the list of sources includes the Wavefolder's own envelope.

Right-clicking on a **target** selector (e.g. where it says 'MIX: Osc A' in the image) opens a menu where you can choose a destination for that modulation source. Effect parameters only appear in the menu if the corresponding effect is currently active.

Drag & Drop is a comfortable alternative (although not for effect parameters, as these aren't visible in [KEYS](#) view). Left-click on the target selector, drag the crosshair onto any knob that is a valid target and release the mouse button.

A few pages down you will find a list of all modulation sources and targets in Repr0-1.

Slot Modifiers

Immediately below the target selectors are buttons used for choosing **slot modifier** options which process the modulation signal before it reaches the target. From left to right these are: *Curve*, *Rectify*, *Quantise*, *Sample & Hold Trigger (S+H)* and *Slew Limiter (SL)*.

Curve

These options let you 'map' the modulation source onto an s-curve. A bipolar ramp e.g. from the LFO or the pitch bender would be directly transformed into one of the following curves, while a positive unipolar source would only use the upper half of each curve:

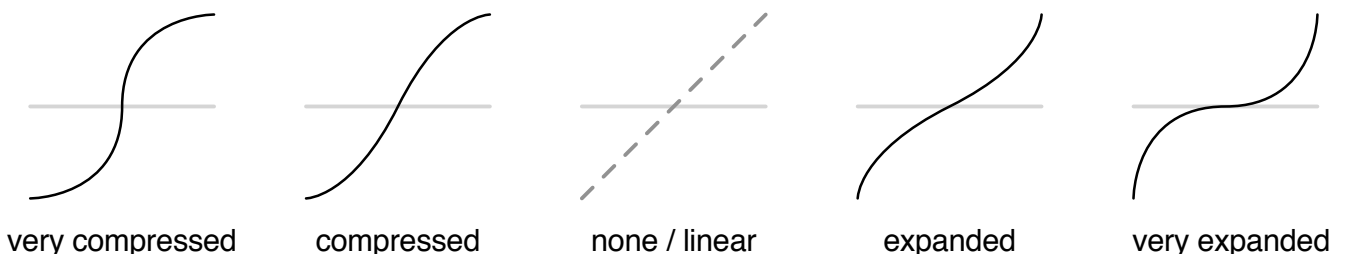

Rectify

Half-wave or full-wave rectification in positive and negative versions, and *unipolarize*. The symbols show how a bipolar ramp wave (like 'none' here) would appear after rectification.

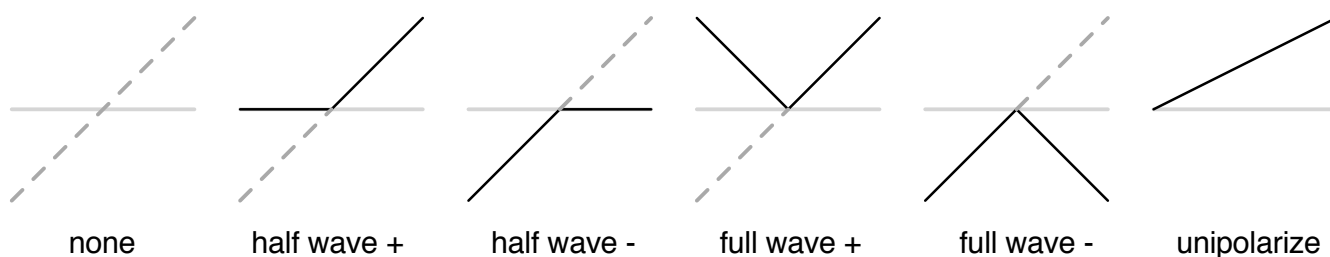

<i>half wave +</i>	removes negative values
<i>half wave -</i>	removes positive values
<i>full wave +</i>	folds negative values up into the positive
<i>full wave -</i>	folds positive values down into the negative
<i>unipolarize</i>	shifts the signal to positive-only and halves the range

Quantize

After applying a curve, the modulation signal can be forced to adopt certain discrete values.

The *integer* setting makes the modulation typically “steppy”. The *steps of 12* option transforms bipolar sources into max. 5 values (unipolar = maximum 3). All other options quantize the output to scales, so they are mainly useful for pitch control.

<i>overtone series</i>	harmonic overtones
<i>minor / major scale</i>	natural minor, regular major
<i>minor / major chord</i>	chord tones (root, third fifth)
<i>minor / major series</i>	third intervals (repeats after two octaves)
<i>fifths and octaves</i>	well, it's fifths and octaves only!

Note: Quantization is applied **after** modulation depth, so lower depth means fewer steps.

Sample & Hold Trigger (S+H)

Mod Wheel, Pitch Wheel, Control A, Control B, LFO, Gate, Aftertouch or *Wavefolder AR*.

Whenever the selected signal crosses zero in the positive direction, the modulation source will be sampled and held i.e. stepped.

Slew Limiter (SL)

Softens transitions in the modulation source. The options are: *none, fast, smooth* or *slow*.

Modulation Sources			
Mod Wheel Pitch Wheel Control A (default = Breath i.e. CC #02) Control b (default = Expression i.e. CC #11) LFO Clock Phase (ramp) Trigger Gate Key Follow 1 Key Follow 2 (doesn't include pitch bend) Velocity Aftertouch Wavefolder AR Filter Envelope Amp Envelope		Oscillator B	Frequency ** Fine Tune Pulse Width
		Modulation	LFO Amount Osc B Amount Filter Env Amount
		Mixer	Osc A Osc B Noise/Feedback
		Filter	Cutoff Resonance Keyboard Amount Envelope Amount
		Jaws	Folds Bias Fold Mod Depth
Modulation Targets			
LFO	Frequency (when the LFO is in RATE mode)	Lyrebird	Delay Time Regeneration Mix
MIDI	Glide Master Tune MW Lower Limit MW Upper Limit	ResQ	Bass Frequency Bass Gain(EQ) Bass Vol (Res) Mid Frequency Mid Gain (EQ) Mid Vol (Res) High Frequency High Gain (EQ) High Vol (Res) Q/Resonance
Filter Envelope	Attack Decay Sustain Release	Drench	Pre-Delay Decay Tone Dry/Wet Mix
Amplitude Envelope	Attack Decay Sustain Release	Sonic Conditioner	Gain Stereo Width Transient
Oscillator A	Frequency * Fine Tune Pulse Width		

* Restricted to the FREQUENCY range, also for technical reasons

6 EFFECTS

6-0 INTRODUCTION

The buttons on the far left of the lower panel toggle between the keyboard and the effects. Click on the EFFECTS button for this view:

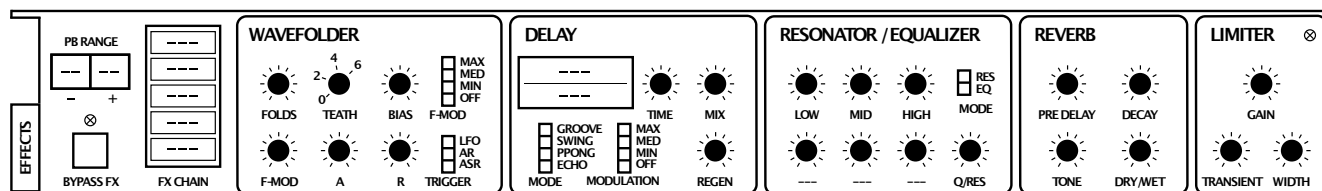

BYPASS FX

This is an effects bypass button you should find useful for comparing the treated and untreated sound. Please note that BYPASS FX is truly global: the status doesn't change, even when you load a different preset.

FX Chain

The block on the left is used for activating and ordering effects. The signal flows from the top of the block to bottom. Click to enable/disable effects, click and drag up or down to change the order. Tip: Placing LYREBIRD above JAWS can get... interesting!

6-1 JAWS wavefolder

Hardware wavefolders have become popular in larger modular systems, especially amongst *West Coast* fans. A special kind of waveshaper, the wavefolder literally folds the waveform back on itself multiple times by mapping the signal onto a multi-toothed curve (see the image on the next page). When applied to a decaying signal, wave-folding can sound similar to FM.

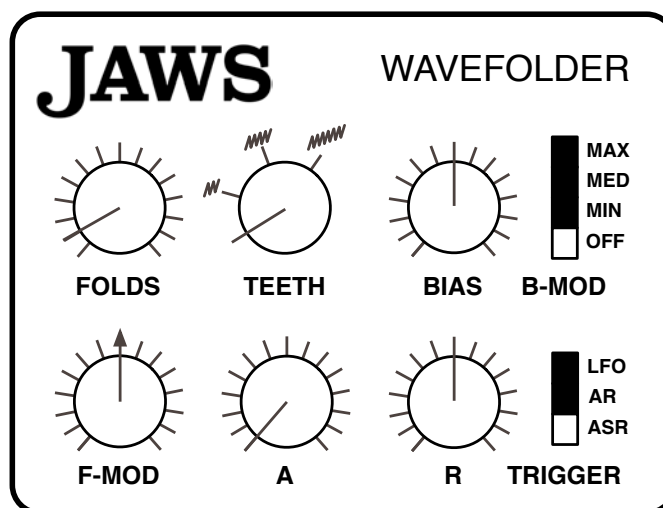

With its set of novel features, however, JAWS has no real world counterpart: Firstly, it includes an envelope to modulate the number of folds and an LFO to modulate the bias *out-of-phase* per audio channel (which results in a unique stereo effect). Secondly, JAWS can serve as a simple distortion unit by setting TEETH (the number of available folds) to zero. Here is a typical wavfolder setting:

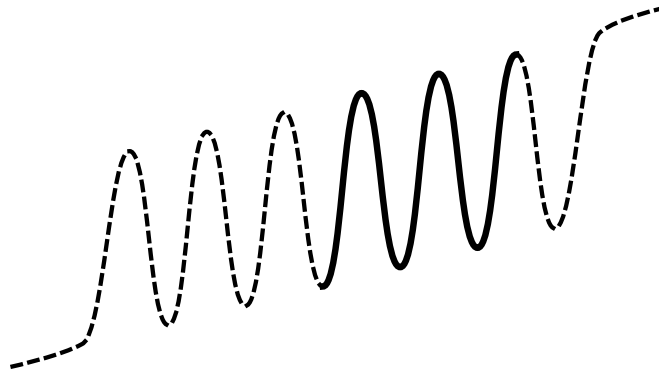

6 TEETH, about 25% FOLDS (the solid line) with some positive BIAS (shifted to the right)

FOLDS knob: How much of the wavefolder curve is being used. This is effectively an input volume control, so setting FOLDS and F-MOD both to zero will result in silence.

TEETH rotary switch: Sets the total number of folds in the wavefolder. Zero here means soft saturation, while the options 2, 4 and 6 are more typical wavefolder effects.

BIAS knob: If B-MOD is *OFF*, this knob shifts the part of the wavefolder curve being used. If B-MOD is either MIN, MED or MAX, it adjusts the depth of modulation from the wavefolder's own LFO – in opposite directions for each stereo channel, hence the stereo effect. Note that the stereo effect is not monosum-compatible, and that extreme BIAS settings can result in silence anyway, especially if FOLDS is set relatively low.

B-MOD switch: Bias modulation LFO rate. Setting this to *OFF* disables the LFO.

F-MOD knob: The depth of folds modulation from the wavefolder's own envelope...

A and **R** knobs: **A**ttack and **R**elease times for the wavefolder envelope.

TRIGGER switch: Determines how the envelope reacts, with the following 3 options: *ASR* stands for *attack-sustain-release* – the envelope proceeds through the attack stage and stays at maximum as long as a note is held, after which it releases. *AR* is a one-shot *attack-release* envelope with no sustain. Finally, the *LFO* option is similar to *AR* but is triggered by Repro-1's main LFO instead of the gate.

Tip: In general, wavefolders deliver more interesting effects when applied to relatively simple waveforms e.g. a pure triangle from oscillator B, a sine wave from the filter when self-resonating, or any other mellow sound.

Note: The sound of the Wavefolder is sensitive to minuscule differences in signal level and phase between the various sample rates. If you notice that your JAWS-based preset sounds very different when you switch sample rates, try adjusting the FOLDS settings to compensate, then save as “name-of-preset (96k)” or similar.

6-2 LYREBIRD delay

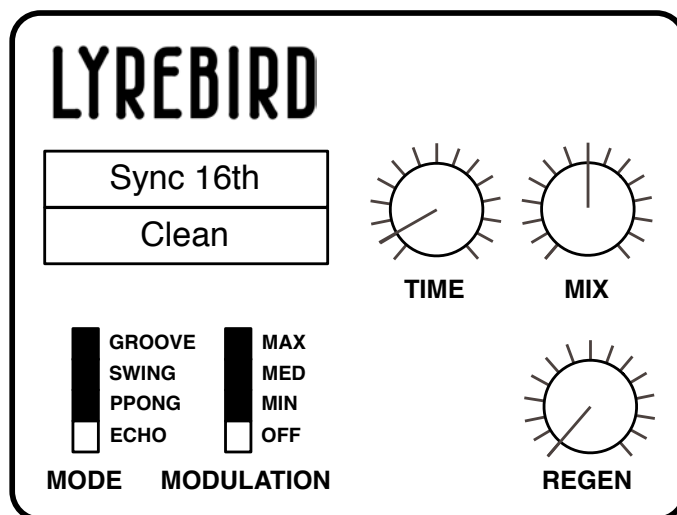

Lyrebird models an analogue (*bucket brigade* type) delay, capable of unsynchronized effects anywhere between flanging (i.e. modulated, very short delays) and 2 seconds, or host-tempo-relative delays between 1/16 and 8/1. In either mode, the delay time can be continuously fine-tuned.

Sync (upper selector): *Chorus/Short*, *Unsync/Long*, *Sync 1/16* or *Sync 1/4*. The first two options are absolute times, not relative to host tempo. As the name implies, the *Chorus/Short* option sounds especially rich with plenty of modulation (see below). *Unsync/Long* is usually the best choice for larger spaces and non-rhythmic effects.

Flavour (lower selector): Three different tonal characteristics for the decaying effect (*Clean*, *Bright* or *Dark*). Try them all out and compare results.

MODE switch: Affects the ratio between delays in the left and right channels: *Echo* has equal delay times in both channels (so the effect is monophonic unless modulated). *Pingpong* alternates evenly between the left and right channels, *Swing* creates triplets and *Groove* does dotted times.

MODULATION switch: Time modulation LFO rate. Switching to *OFF* disables the LFO.

TIME knob: Scales the Delay Sync value. For the synchronized delays this is literally a 1 to 8 multiplier, while for unsynchronized delays the range is much wider. Tip: Try turning REGEN up and modulating TIME – the pitch glides very smoothly, just like a real analogue or tape delay unit.

MIX knob: The volume ratio between unprocessed and processed signal.

REGEN knob: *Regeneration* determines how much of the processed signal is fed back into Lyrebird's input. At maximum, the feedback lasts longer than you will ever need!

6-3 RESQ resonator / equalizer

Depending on the status of the MODE switch, RESQ is either a semi-parametric EQ with two shelving filters surrounding a midrange band, or a triple bandpass resonator:

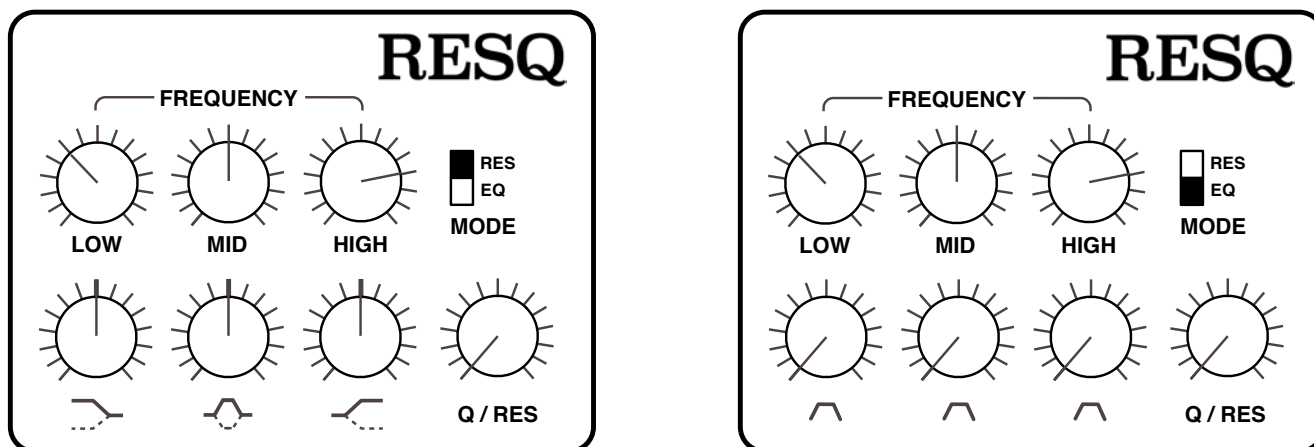

The **FREQUENCY** knobs adjust the cutoff for each band. The bands can seriously overlap or swap positions, so those labels shouldn't be taken too literally. The ranges of the knobs are approximately as follows:

LOW	=	45 Hz to 3 kHz
MID	=	55 Hz to 9 kHz
HIGH	=	130 Hz to 10 kHz

GAIN knobs (EQ mode): Centre-zero controls for cutting or boosting the level of each band by up to 18dB. In EQ mode, LOW and HIGH are shelving filters (as indicated by the labels).

VOLUME knobs (RES mode): The amplitudes of three resonant bandpass filters. The knobs are not centre-zero in RES mode, but positive only.

Q (quality) / RES (resonance) knob: The *Q-factor* of a filter band characterizes its width relative to its cutoff frequency. In EQ mode, Q only applies to the MID band.

6-4 DRENCH reverb

A typical lush plate reverb, but with pre-delay.

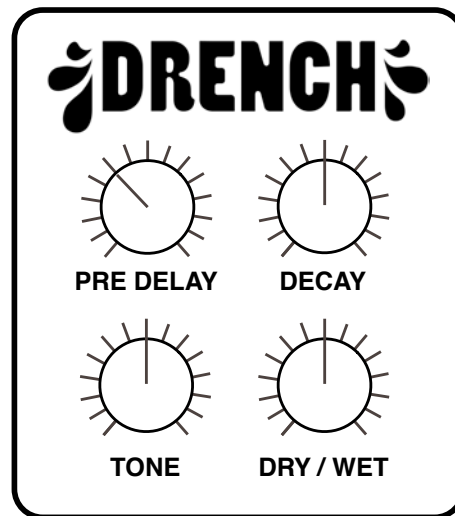

DRY/WET knob: The amount of reverb signal as a percentage of the total output.

PRE DELAY knob: A single delay before the reverberation appears. This is especially useful for retaining the presence of the dry signal while simulating larger spaces. Conversely, leave this at zero if you want your preset to sound further away.

DECAY knob: The length of the reverb tail. At the maximum setting (100), it can take several minutes for the decay to reach absolute silence.

TONE knob: A tilt filter, from very dark at -100 to very bright at +100. TONE simulates the softness / hardness of surfaces. Note: At such extremes values, the wet signal almost (but not quite) disappears.

6-5 SONIC CONDITIONER

Is the signal too loud or too soft? Is the stereo too extreme? Is your bass sequence too clicky, or does it lack punch? Then you should try the SONIC CONDITIONER...

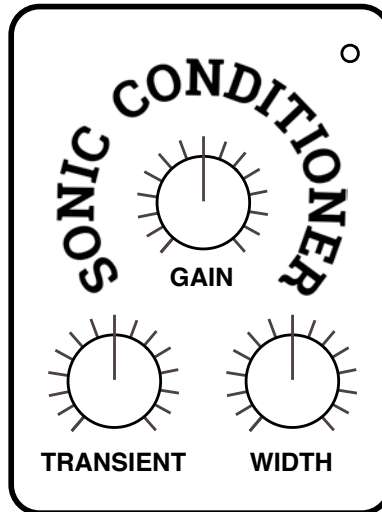

On the top right is a load indicator which gets brighter as the signal is saturated.

GAIN knob: Bipolar control for the output level. Settings above zero (the centre) will saturate the signal – a useful effect in its own right. You can compensate for high GAIN by turning Re-pro-1's main OUTPUT level down.

TRANSIENT knob: Bipolar control over the percussive elements within a signal. Try setting negative values to reduce clicks or positive values to add punch.

WIDTH knob: A stereo spread control. Especially useful for keeping delay or bias- modulated wavefolder effects more focussed in the centre of the stereo field.

7 TWEAKS

7-0 OVERVIEW

Apart from being unashamed eye-candy, the TWEAKS page is there to let you change the fundamental behaviour of individual modules. In the current version there are 5 user-adjustable **jumpers** (mini circuit connectors) and 5 **module tweak** selectors:

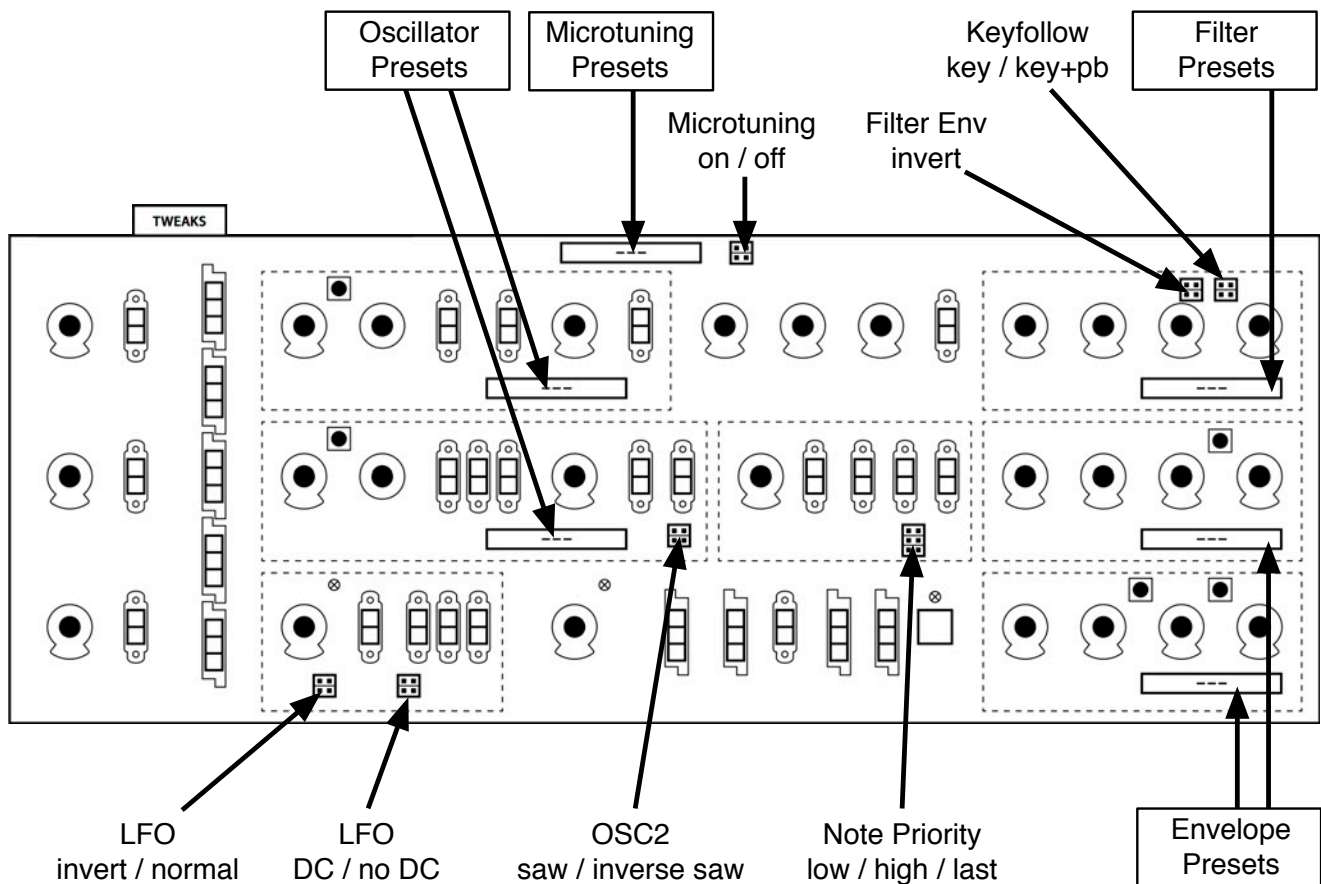

Although the knobs and switches do actually work, the labeling has been kept simple (or even cryptic) on purpose, in keeping with the 'circuit board' theme...

The TWEAKS page is meant to be eye-candy!

7-1 JUMPERS

LFO inversion: In the N (normal) position the LFO is a rising sawtooth, just like the audio oscillators, while in the INV position it is a falling sawtooth. The new option is arguably more useful than the original.

LFO DC offset: With the jumper in the DC position, the square and saw waves are positive-only (unipolar). The NO DC option makes them bipolar. The LFO triangle is always bipolar, with just a little DC offset when the jumper is in the DC position.

OSC2 saw inversion: With the jumper in the INV position, the sawtooth is inverted i.e. it becomes a regular sawtooth instead of the original ramp wave.

Microtuning on/off: Activate/deactivate the selected microtuning table (see below).

Note priority: This jumper sets how Repro-1 reacts when you play more than one note at a time. LOW plays the lowest note (like the original hardware as well as other USA-designs), HIGH plays the highest note (EMS and most Japanese synths), LAST plays the most recent note (modern, typical of digitally controlled synths).

Key Tracking Source: With this jumper in the KEY+PB position, cutoff also tracks the pitch bender (PB).

7-2 SELECTORS

Apart from the jumpers, the TWEAK page includes 5 selectors – one for each oscillator, one for the filter and one for each envelope. Use these to change those fundamental characteristics of Repro-1 that would have been “overkill” on the main SYNTH page. Here’s what we have:

Oscillator tweaks

Both ‘P’ options are warmer than the standard *Ideal*. The most obvious difference between P1 and P5 is that the P5 pulse is inverted (that’s why P5 is much louder than P1 if you use Saw and Pulse simultaneously). A less obvious difference is that OSC A in P1 mode always retains some of the fundamental frequency when SYNC is on.

A disadvantage of P5 is that self-PWM of oscillator B simply doesn't work. You already guessed that ‘P5’ was named after a closely related polyphonic synthesizer, right?

Finally, only available in OSC B: the *Bottom* option emphasizes the TRIANGLE shape.

Microtuning

Repro-1 supports standard .TUN microtuning tables, and you will find several of these files in the list. Many more tables are available online, most of them free. The .tun files belong in the following folder on your hard drive:

Win C:\Users*YOU*\Documents\u-he\Repro-1.data\Tunefiles\

Mac Macintosh HD/Library/Application Support/u-he/Tunefiles/

...or equivalent locations in accordance with your VST and Repro-1 installation paths.

Just like in the main browser you can right-click on any .tun file and select *Show in Finder/Explorer*. To close the microtuning browser again, click on the [CLOSE] button at the top right.

New in version 1.1.2 – MTS-ESP

Repro-1 now supports Oddsound MTS-ESP, a system for microtuning multiple plug-ins within a DAW environment. The freeware ‘Mini’ version is all you need to get started. MTS-ESP can be overridden by activating Repro-1’s microtuning, for instance with the .tun file *Default Scale*.

Filter tweaks

Crispy: This is an accurate model of the filter in one of the hardware synths we bought especially for Repr0-1 analysis. It is relatively clear and bright.

Rounded: An accurate model of the filter in the other hardware synth we bought especially for Repr0-1 analysis! Most obviously, the cutoff in *Rounded* is a few semitones lower than *Crispy*, and there are also significant differences in the resonance behaviour

Driven: This model is the result of balancing internal filter parameters in search of a novel 3320 flavour – we like it!

Poly: An approximation of the filters in a related polysynth. In this model, cutoff doesn't reach maximum unless modulated upwards e.g. by the filter envelope.

Envelope tweaks

Normal: Regular old ADSR.

High Sustain: Models an interesting fault (or is it a quirk?) in some versions of the original hardware: the end of the ATTACK doesn't quite reach SUSTAIN levels above about 85 – the envelope simply jumps up the last 15%.

One Shot: The gate is ignored, the Decay stage continues until it reaches the sustain level, which is immediately followed by Release. This type of envelope is particularly suitable for percussion sounds, fly-by effects etc..

Piano 1/2: These two modes were implemented according to a rather geeky article in the magazine *Electronics and Music Maker* (affectionately known as *E&MM*) all about the CEM 3310 envelope chip. In both *Piano* modes the Attack and Decay stages are the same as in *One Shot* mode. However, if the key is lifted during the Release stage there is an extra (true) re-lease, which is longer in *Piano 1* than in *Piano 2* mode.

Tip: As the Attack and Decay stages are always completed, you can make an envelope appear to hold for a while before it releases!

8 CONFIGURATION

The **cogwheel** at the top right opens the global configuration pages. This is where you can adjust Repro-1's appearance and performance or connect Repro-1 parameters to MIDI controls:



You can specify which particular page (e.g. PREFERENCES) will open whenever you click on the configuration button: Right-click anywhere in this row and select *set current as default*.

8-1 ABOUT MIDI CC

CC, which now officially stands for Control Change (no longer Continuous Controller) is a multi-purpose message format used for editing and performing presets. CC isn't the only kind of MIDI performance data. For instance, there are different messages for note on/off (including velocity), pitch bend and two kinds of aftertouch.

Although the MIDI Manufacturers Association (MMA) was kind enough to leave most of the 128 CC numbers undefined, two have specific meanings that Repro-1 also recognizes:

- 01 = modulation wheel
- 64 = sustain pedal

Repro-1 version 1.0 also offered the performance modulation sources *Breath* (CC 02) and *Expression* (CC 11). These have been replaced by the user-definable *Control A* and *Control B*. See section 8-4 [PREFERENCES](#).

By the way: You don't actually need a breath controller (for instance) or an expression pedal to make use of CC messages. Most of the names are purely convention these days. You can use anything that can send a definable CC e.g. a couple of knobs on your MIDI keyboard or a controller lane in your MIDI sequencer.

Later MMA revisions to the MIDI spec even included a bunch of esoteric CC definitions such as 'Celeste Detune Depth', probably at the request of a home organ manufacturer or two. We can safely ignore all such definitions!

8-2 MIDI LEARN

The MIDI LEARN page is where you can connect MIDI CC (see above) to almost any Repro-1 parameters. The MIDI data can be generated by adjusting the knobs or faders on a hardware controller, for instance, or by a track in your sequencer.

Learnable elements appear as selectable outlines. Controls that are already connected appear filled, while the outline of the control waiting to be MIDI-learned is highlighted white.

Try it: Click on the Cutoff knob (it is then highlighted) and send Repro-1 some MIDI CC data by adjusting a knob or fader on your MIDI controller. To remove the assignment, double-click on that same control or go to the MIDI Table (see below).

Note: You can access all parameters without exiting MIDI LEARN. Simply switch between the SYNTH, TWEAKS and SEQUENCER pages, or between the KEYS and EFFECTS.

8-3 MIDI TABLE

To open an editable list of all current MIDI CC assignments, click on the cogwheel button and select MIDI TABLE.

Parameter: The first field displays/selects one of Repro-1's parameters, sorted into sub-menus according to module. Click on the 'ADD' button at the bottom left and experiment with this field, then delete the assignment again by clicking on the small [X] to the right of the line you just created.

Channel / Controller: The next two fields are for the MIDI channel and CC number. Repro-1 is channel-sensitive – you can map up to 16 channels for a total of... well, more than enough assignments for Repro-1.

Mode: Specifies the range and/or resolution of values.

Normalfull range, continuous

Integerfull range, whole numbers only

Fine0.01 steps between the integers closest to the current value

Type: Specifies the type of hardware (by far the most common is *Continuous 7-bit*).

Encoder 127‘relative mode’ endless rotary controls that repeatedly send the CC value 1 when turned in the positive direction, or 127 (interpreted as -1) when turned in the negative direction

Encoder 64‘relative mode’ endless rotary controls that repeatedly send the CC value 65 when turned up, or 63 when turned down

Continuous 7-bit7-bit MIDI CC (normal resolution, very common)

Continuous 14-bit14-bit MIDI CC (high resolution, less common)

Removing assignments: The small [x] to the right of each line removes that assignment. The MIDI table can be cleared by clicking on the [Delete All] button at the bottom of the window.

Experimental feature: Click on **Add**. At the very bottom of the *Parameter* menu you will see two options called *Last Clicked Control* and *Last Clicked Control Fine...*

Select *Last Clicked Control*, enter a suitable controller (MIDI CC) and exit the configuration pages. The most recently clicked knob/switch will now respond to that CC. The *Fine* option is similar, but with a significantly reduced range.

Per Instance Control: The panel to the right of the MIDI TABLE offers local versions of the *Control A Default* and *Control B Default* settings i.e. for the current instance only. As these override the global versions, they are particularly useful while controlling multiple instances.

Click on the [Set as Default] button to copy these settings to the global preferences.

8-4 PREFERENCES

To see the following options, click on the cogwheel icon at the top right of Repro-1's window and select the PREFERENCES tab.

CONTROLS

Mouse Wheel Raster: If your mouse wheel is rastered (it clicks as you roll the wheel), set this option 'on' so that each little click increments the value in 'sensible' steps.

Scroll Horizontal: Any preset folders that contain more files than can be displayed in the window can be scrolled pagewise via mousewheel etc.. Opinions differed as to which wheel direction should move to the bottom of the list, so we made this optional!

Switch behaviour: You can usually change the status of linear switches by clicking on the target position. The *drag* option lets you drag switches up/down while *toggle* lets you click anywhere on 2-way switches. The *iterate* option is like *toggle* except that it also applies to 3 and 4-way switches, with the downside that clicking on the target position no longer works. Note: Switches always respond to rolling the mouse wheel just like the knobs – no clicks required!

APPEARANCE

Default Size: The GUI size for each new instance of the plug-in.

Default Skin: This option will only appear if Repro-1 finds at least one alternative skin when it loads. Change this option to set the global default.

Gamma: Adjusts the overall brightness of the Repro-1 window.

Text Antialiasing: Turns the smoothing of labels and values on or off. Usually left on!

PRESETS

Auto versioning: If this option is switched on, an index is appended to the preset name and automatically incremented each time you save it. For instance, saving 'Space' three times in a row would give you three files: 'Space', 'Space 2' and 'Space 3'.

Save Presets To: Choosing *user folder* here causes all saved presets to land in the *User* folder instead of the currently selected one.

Scan On Startup: Whether the preset library should be scanned and the database recreated when the first instance of Repro-1 is started, e.g. when you reopen a project.

OTHERS

Base Latency: Only disable this if you are absolutely sure that your audio system – hardware as well as software – uses buffers that are a multiple of 16 samples. Otherwise you should leave it at the default '16 samples'. This setting only takes effect when the host allows e.g. on playback, after switching sample rates, or after reloading Repro-5. See the information box on the next page "About the Repro-1 Buffers".

Control A/B Default: The list of modulation sources in the previous versions of Repro-1 included the fixed MIDI control sources Breath (CC#02) and Xpress (expression pedal, CC#11). While retaining backwards compatibility, we replaced them with the user-definable *Control A* and *Control B* performance sources, with Breath and Expression set as the defaults.

HQ default: Set whether *HQ* should be *on* for each new instance of the plug-in. *High Quality* is seldom necessary – you can save a significant amount of CPU if you leave this switched off.

MIDI Control Slew: Adjusts the amount of ‘smoothing’ for Pitch Bend, Modulation Wheel, Control A, Control B and Aftertouch. While set to *Off*, Repro-1 responds more quickly to modulation wheel (for instance), but might become too grainy for your tastes. The *Fast* setting is a good compromise between response and smoothness.

Sequencer Root Note: The default *auto* option here sets the pattern’s *Root* to the first note you record. If you prefer setting the Root Note *manually*, select that option.

Sleepy default: Set whether *Sleepy* should be *on* for each new instance of the plug-in. See the zZz button in section 1-4 CONTROL BAR.

ABOUT THE REPRO-1 BUFFERS

Repro-1 processes audio in chunks of $n \times 16$ samples. This *block processing* method significantly reduces the CPU load and memory usage of all our plug-ins.

If the number of samples to be processed is e.g. 41, Repro-1 processes the first 32 and keeps the remaining 9 in a small buffer (16 samples is large enough). Those 9 samples are then processed at the start of the next call... and so on.

The extra buffer is only necessary if either the host or audio driver processes ‘unusual’ buffer sizes. If your host application processes buffers of e.g. 64, 128, 256 or 512 samples (these are all multiples of 16), try setting Base Latency to *off* so that Repro-1 can process latency-free.

9 NKS

Repro-1 supports Native Instruments (NI) **NKS extensions** for VST. All Windows audio plugin hosts and certain macOS hosts can load VST.

This means that Repro-1 can be integrated into the **Komplete Kontrol** software or **Maschine** environments: As well as the u-he cross-platform h2p formats, you can also install the factory presets as tagged **.nksf** files. In the VST version only, *nksf* also appears in the context menu of the [SAVE] button.

As we wanted to keep them synth-specific, the *Category* options (see [PRESET BROWSER](#)) differ from the Komplete Kontrol / Maschine *Type* tags. During conversion to NKS (see below) Repro-1 automatically converts *Category* tags to the closest corresponding *Type*.

In Komplete Kontrol / Maschine, any untagged presets will appear in *Synth Misc*.

Presets saved in NKS format do not appear in Repro-1's browser!

Saving as nksf

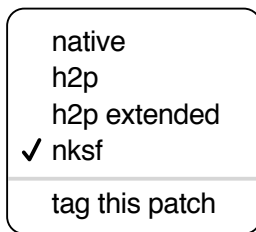

Right-clicking the [SAVE] button opens a small menu offering a choice of several preset formats.

While the *native*, *h2p* and *h2p extended* formats allow Repro-1 to save presets into the currently selected folder, choosing *nksf* causes them to land in a location specified by NI. For more detailed information, please refer to Native Instruments' own NKS documentation.

Conversion to nksf

Set the format to *nksf* by right-clicking on the [SAVE] button and choosing the *nksf* option. Open Repro-1's browser, select the presets you want to convert, right-click on one of them and choose *convert to nksf*. A text message appears telling you how many were converted and how to update the Komplete Kontrol database. During conversion, a few pages of performance controls mapped to common parameters are generated and saved with each *.nksf* preset.

If you encounter any problems, see the next page, [Troubleshooting](#).

10 Troubleshooting

10-1 NKS

Repro-1 doesn't appear in Komplete Kontrol / Maschine

Firstly, make sure you have Komplete Kontrol Software V1.5+ or Maschine V2.4 – the minimum requirements for our implementation of NKS.

Under Windows, Komplete Kontrol needs to register the location of Repro-5's VST file: Open the Komplete Kontrol preferences, go to *Locations* and add the directory that contains either Repro-1(x64).dll or Repro-1.dll (as specified during Repro installation). Hit *Rescan* and check whether Repro-5 appears.

If the NKS preset folder is empty you should reinstall Repro with the correct VST path and the NKS-option checked. Here are the preset folder locations:

Mac *MacHD/Library/Application Support/u-he/Repro-1/NKS/Repro-1/*

Win *C:\Users*YOU*\Documents\u-he\Repro-1.data\NKS\Repro-1*

Perhaps the XML-File is missing from the following path:

Mac *MacHD/Library/Application Support/Native Instruments/Service Center/u-he-Repro-1.xml*

Win *C:\Program Files\Common Files\Native Instruments\Service Center\u-he-Repro-1.xml*

A re-install with the NKS-option checked should also resolve this issue.

Error message “Could not load plug-in (plug-in not found)”

Repro-1's VST file is not in the directory specified by the Komplete Kontrol preference. Reason: Either Repro-1 wasn't installed as a VST, or it wasn't installed with the correct path. Note that the VST path is fixed in OSX but is user-definable in Windows:

Mac *Macintosh HD/Library/Audio/Plug-Ins/VST/u-he/*

Win *<User VST Folder>/* (path for the VST plug-in used during installation)

If the VST plug-in isn't in this directory you will need to reinstall Repro-1 with the VST option checked and the correct VST path.

10-2 DC Thump

In certain hosts a Repro-1 track can start with a noticeable DC offset, which fades within about half a second. This effect is typical of analogue circuitry when first switched on, and it therefore also affects component-level models. Seldom noticed in hardware synths as they are not switched off each time a song is stopped, DC thump can become a problem in VA models.

Solution: Start your song with an empty bar or two so that Repro-1 is "switched on" well before the first note in the song arrives. If that doesn't help, it's likely that the host application doesn't process any plugins before the first note is played. In such cases you should try placing a “dummy” note well before the song begins.